

# Formagenda

FORMAGENDA

Versatility is key to us and we believe that diversity is eclipsing all homogeneous manifestations. Where there is light, there is shadow. And all the shades that interplay in between. Therefore, we asked a wide array of photographers from across Europe to show us how they see our universe. The products were assigned by lottery and the anti-briefing guaranteed a maximum of artistic freedom. Different daytimes, different latitudes, different contexts came together in one result: a kaleidoscopic<sup>1</sup> whirlpool of THE NEW ENLIGHTENMENT.

KALEIDOSCOPE<sup>1</sup>

#### Contributing Artists

P . 31	Alexander Fthenakis	CHAPLIN Table	☉ P . 62
P . 44	Aylin Langreuter	DON CAMILLO Table	☉ P . 90
P . 43	Bettina von Zwehl	PEARLS Table	☉ P . 34
P . 20	Carina Pilz	PEARLS Suspension	☉ P . 10
P . 15 , 25 , 30 , 37	Constantin Mirbach	PROFILE Floor Vertical	☉ P . 48
P . 23	Daniel Mayer	PEPPONE Table	☉ P . 106
P . 33	Denis Pernath	PEPPONE Table	☉ P . 106
P . 7 , 28 , 47	Gerhardt Kellermannn	PROFILE Table 47	☉ P . 56
P . 11 , 29 , 39	Hannes Rohrer	PEARLS Double Table	☉ P . 38
P . 24 , 41	Johannes Bauer	COPPOLA Chandelier 3	☉ P . 80
P . 10 , 46		MIRROR Wide Suspension	☉ P . 124
P . 9 , 22	Jörg Koopmann	CHAPLIN Wall	☉ P . 66
P . 35	Kaveh Kasravi	COPPOLA Table	☉ P . 84
P . 40		COPPOLA Suspension	☉ P . 76
P . 18 , 19 , 36	Magnus Lechner	PEPPONE Wall	☉ P . 110
P . 4 , 21	Manuel Nieberle	CHAPLIN Floor	☉ P . 70
P . 38 , 42	Markus Jans	PROFILE Floor Horizontal	☉ P . 52
P . 5 , 12	Michael Wong	PEARLS Double Suspension	☉ P . 16
P . 16	SCHMOTT Studios	MIRROR Square Suspension	☉ P . 120
P . 6 , 26		PEARLS Double Chandelier 3	☉ P . 26
P . 8 , 34	Sima Dehgani	E.T. Table	☉ P . 100
P . 17		PEARLS Wall	☉ P . 30
P . 27	Sonja Müller	PEARLS Chandelier 3	☉ P . 20
P . 45	Thomas Nutzl	COPPOLA Table	☉ P . 84
P . 14	Tibor Bozi	E.T. Table	☉ P . 100
P . 13	Unterteller	PROFILE Suspension 120	☉ P . 44
P . 32	Zelinda Zanichelli	PEARLS Table	☉ P . 34

<sup>1</sup> Literally, this campaign became the “observer of beautiful forms” (Greek kalos, “beautiful,” eidos, “shape,” and “skopéō”, “look). We hope you agree.

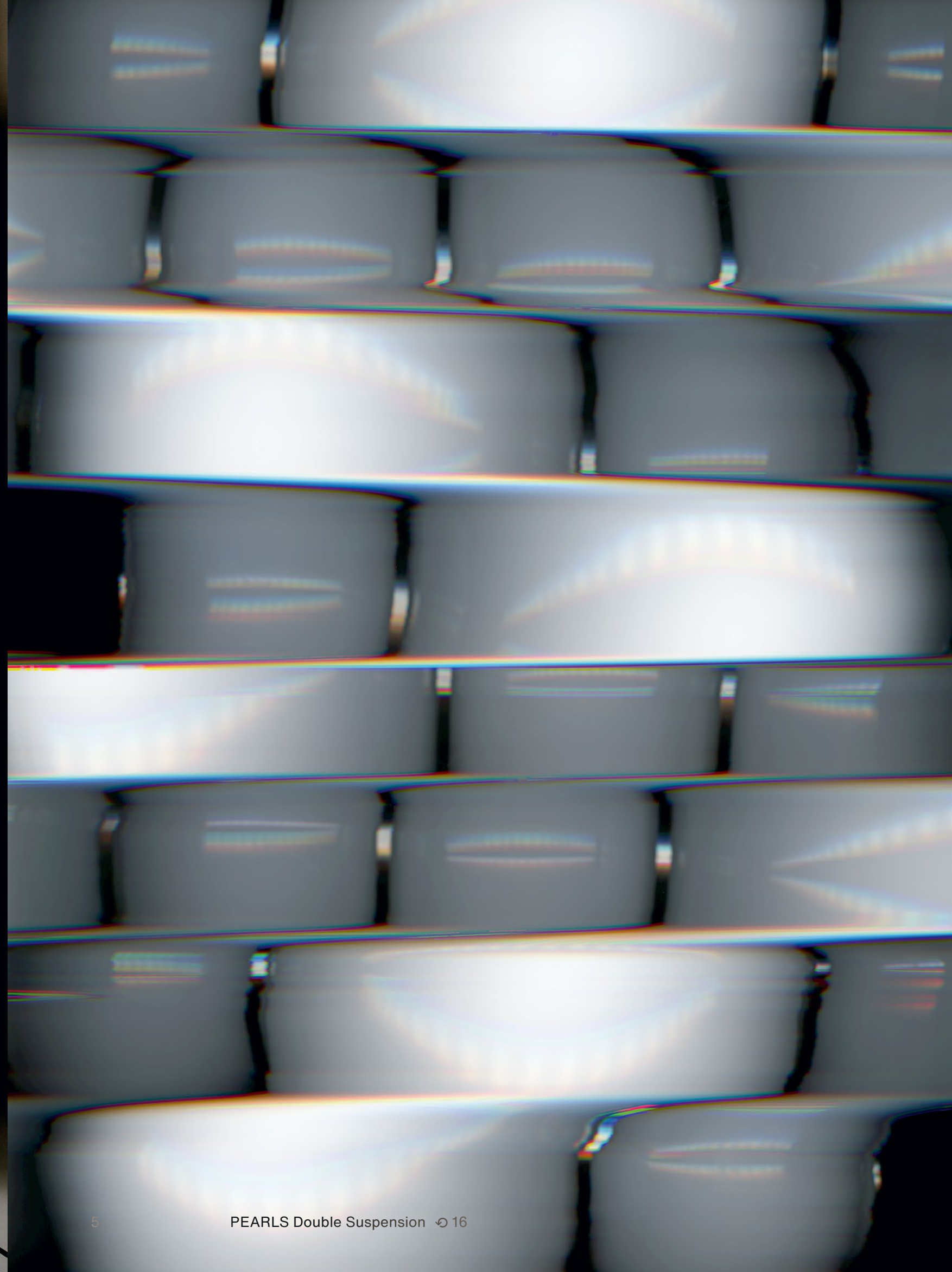





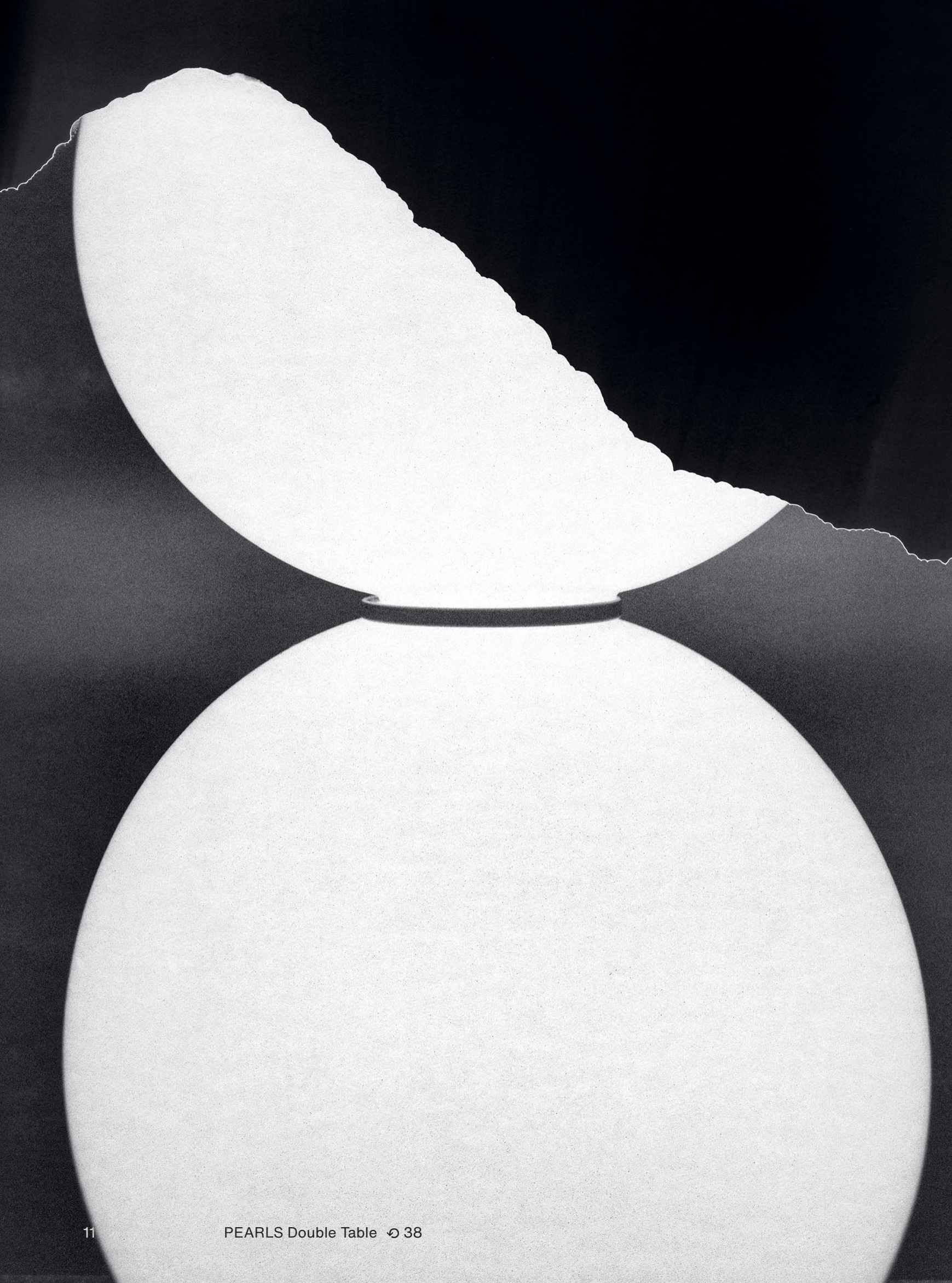







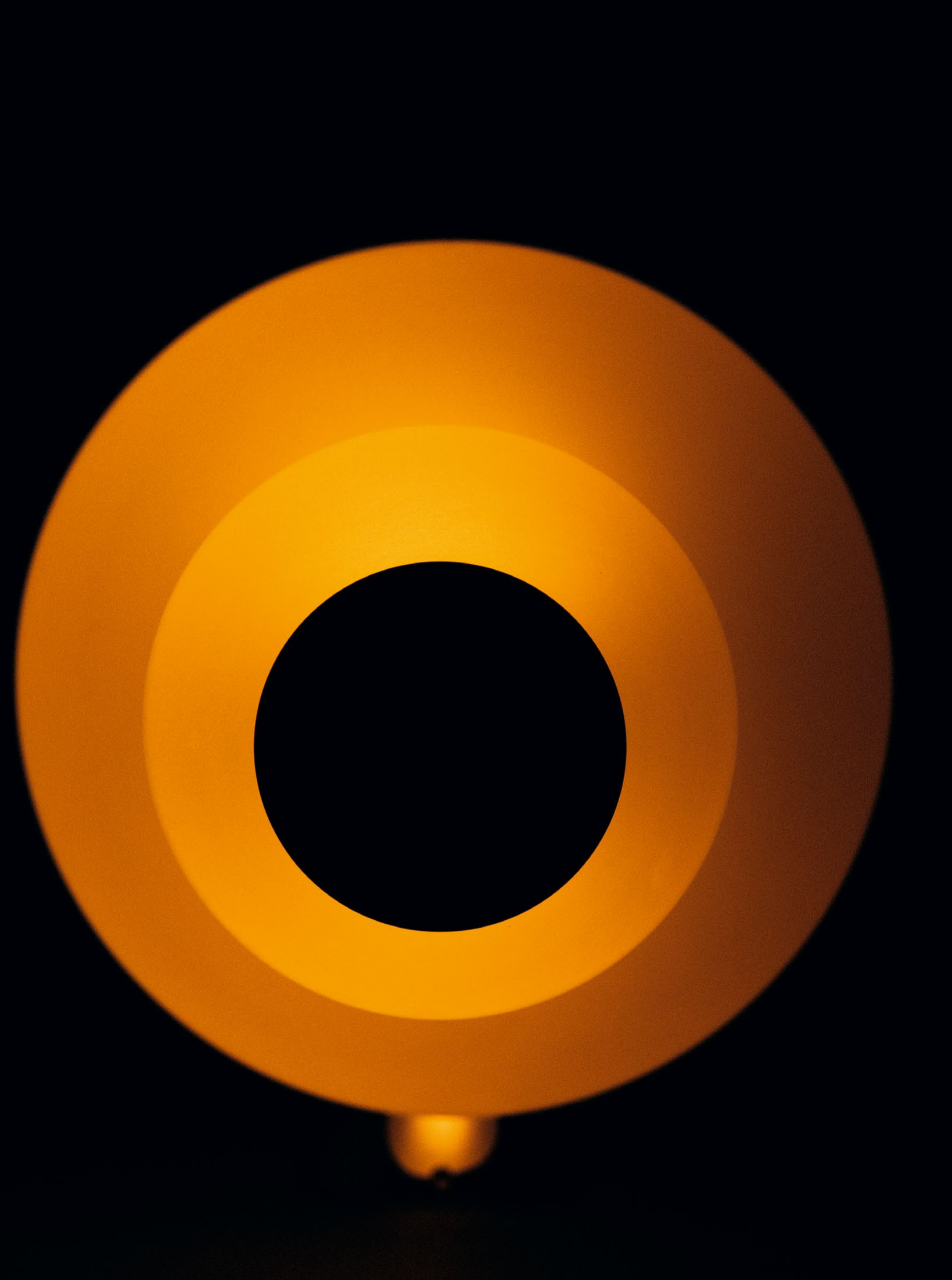
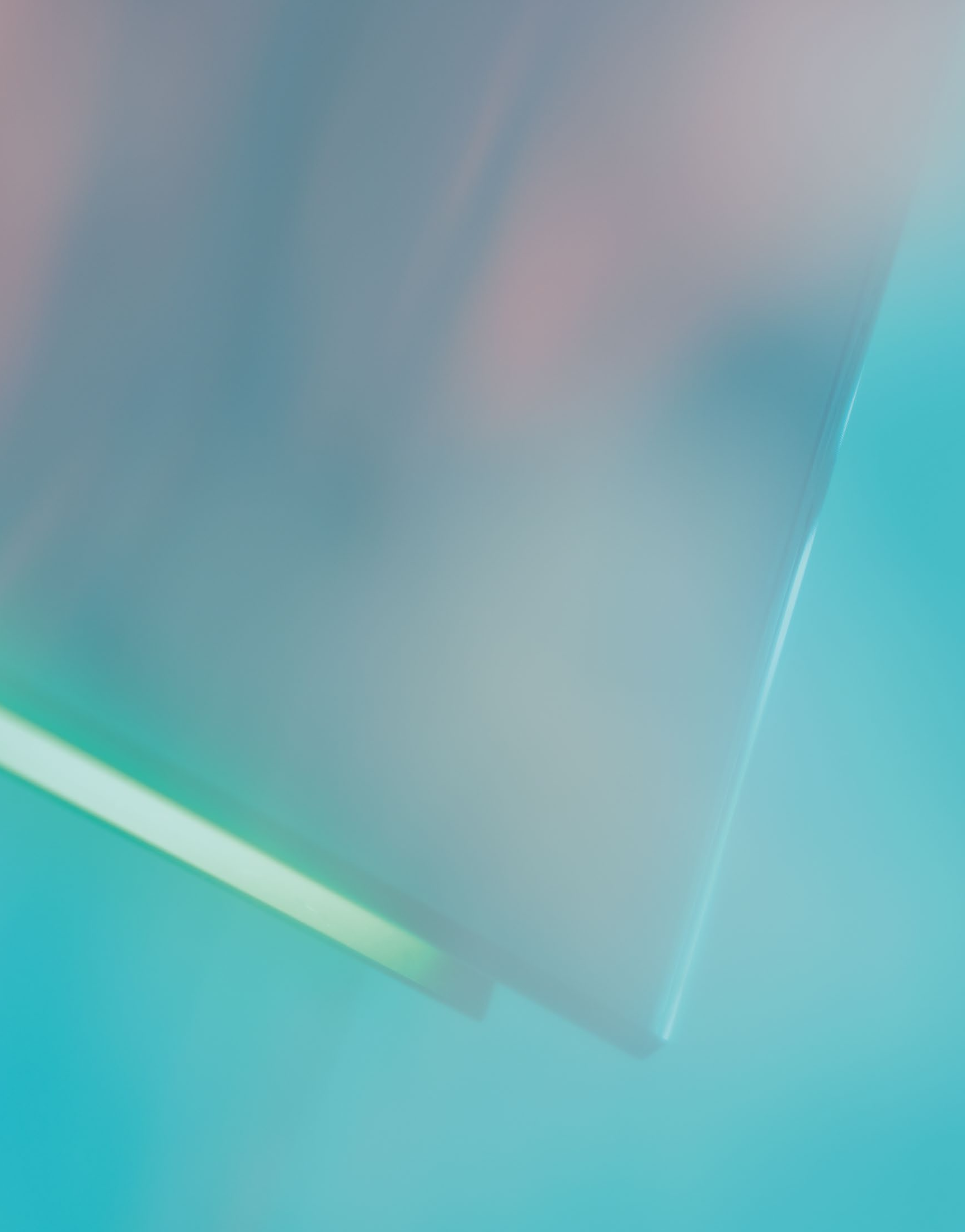





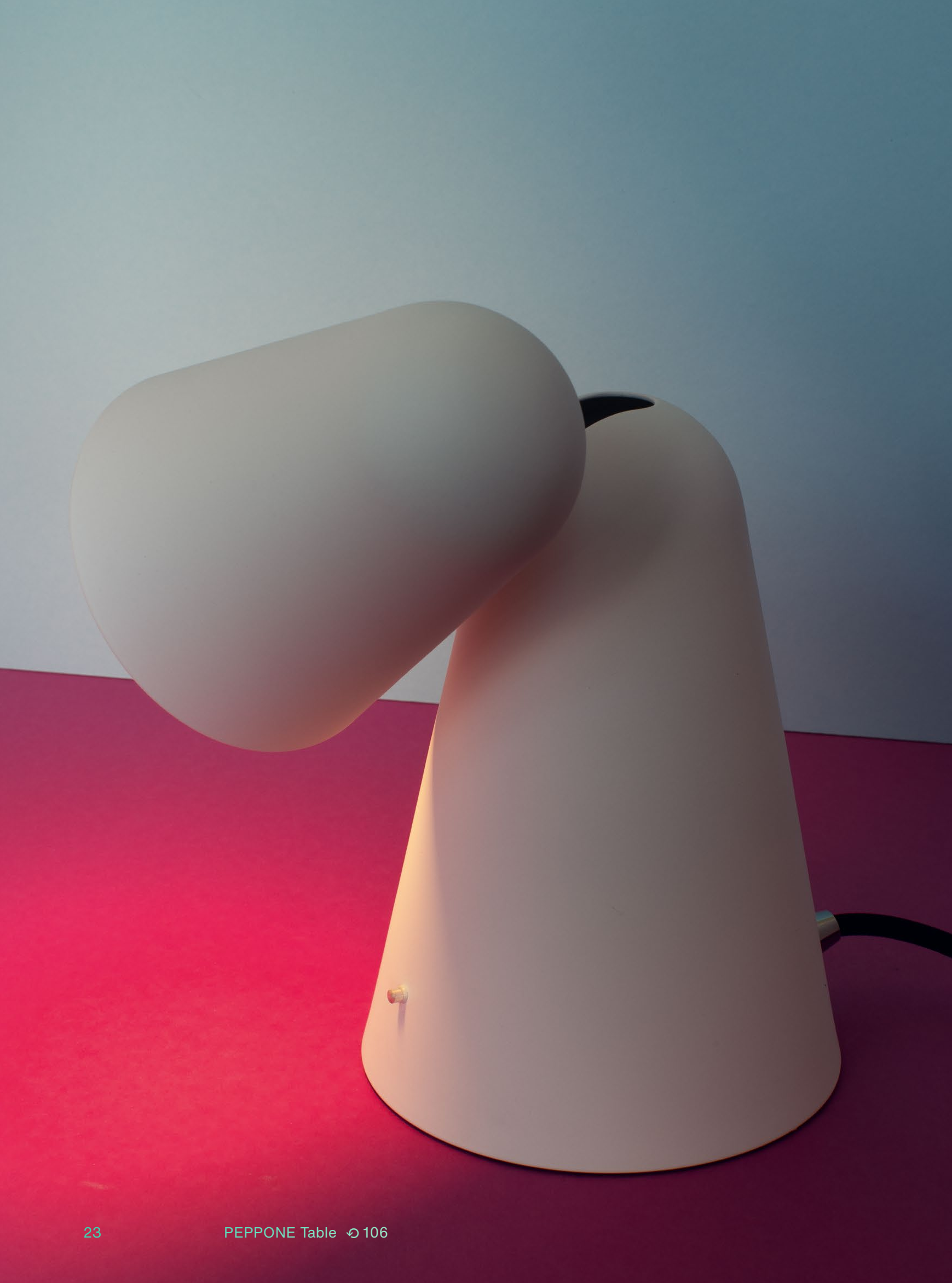

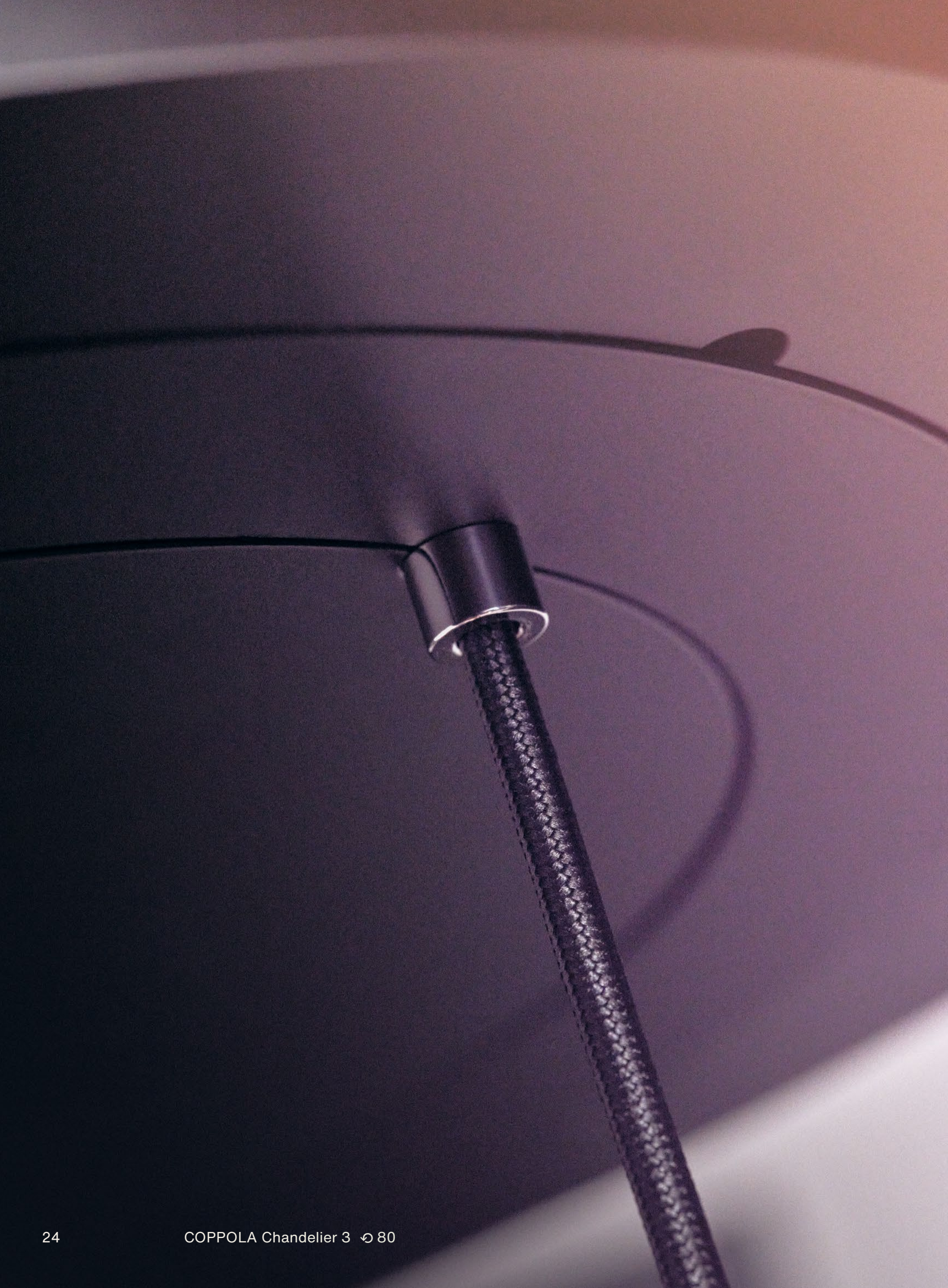

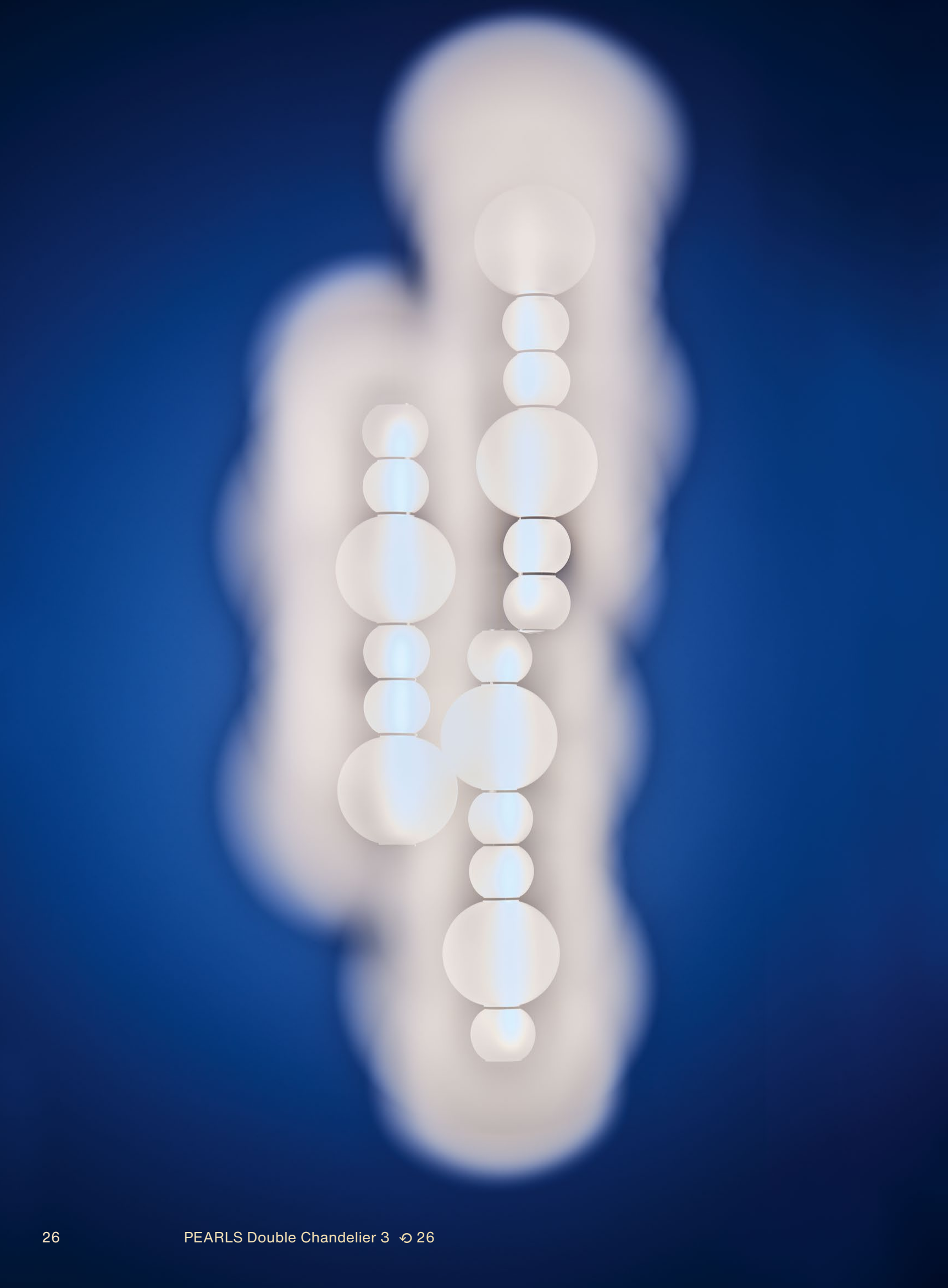











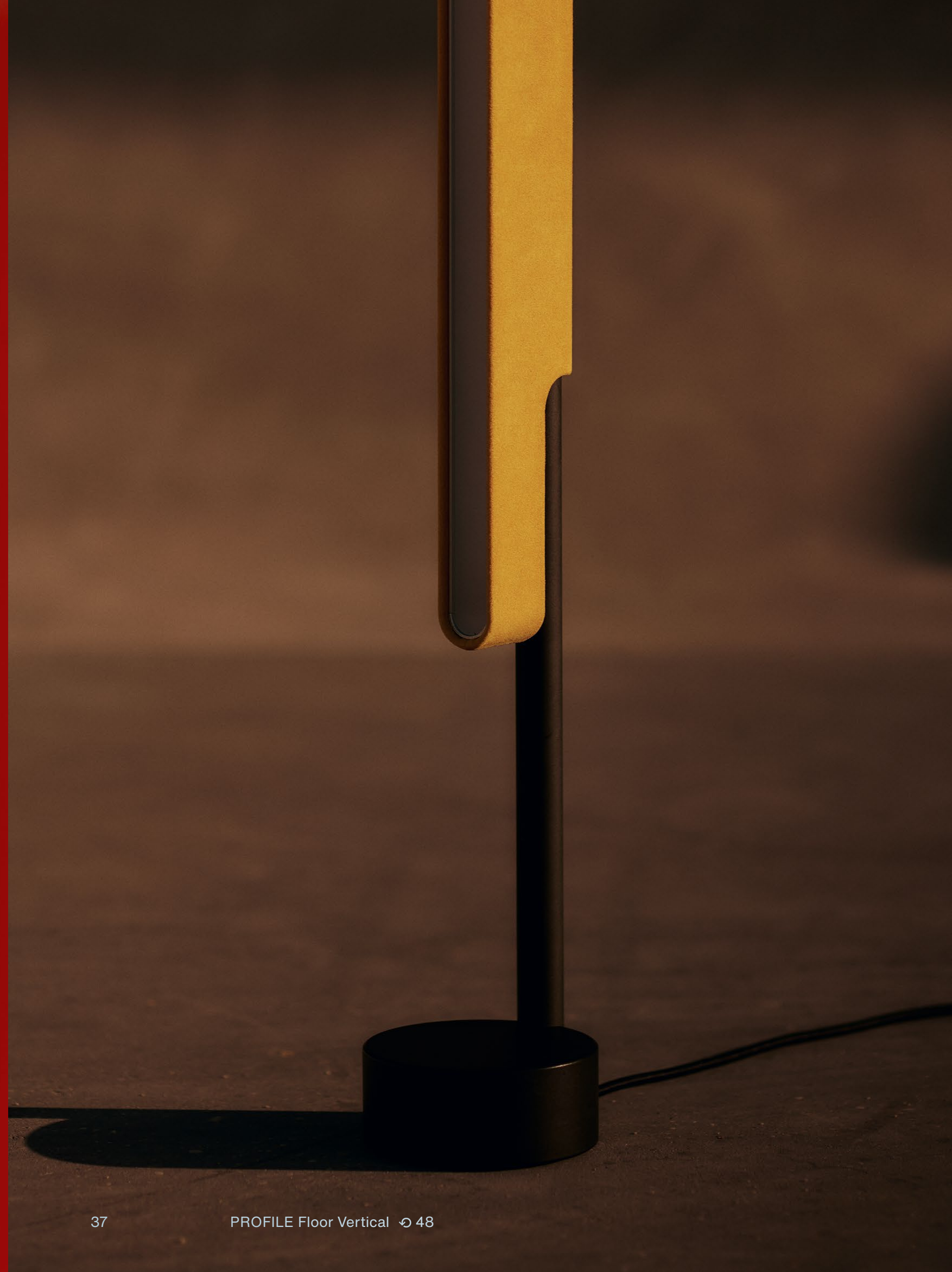

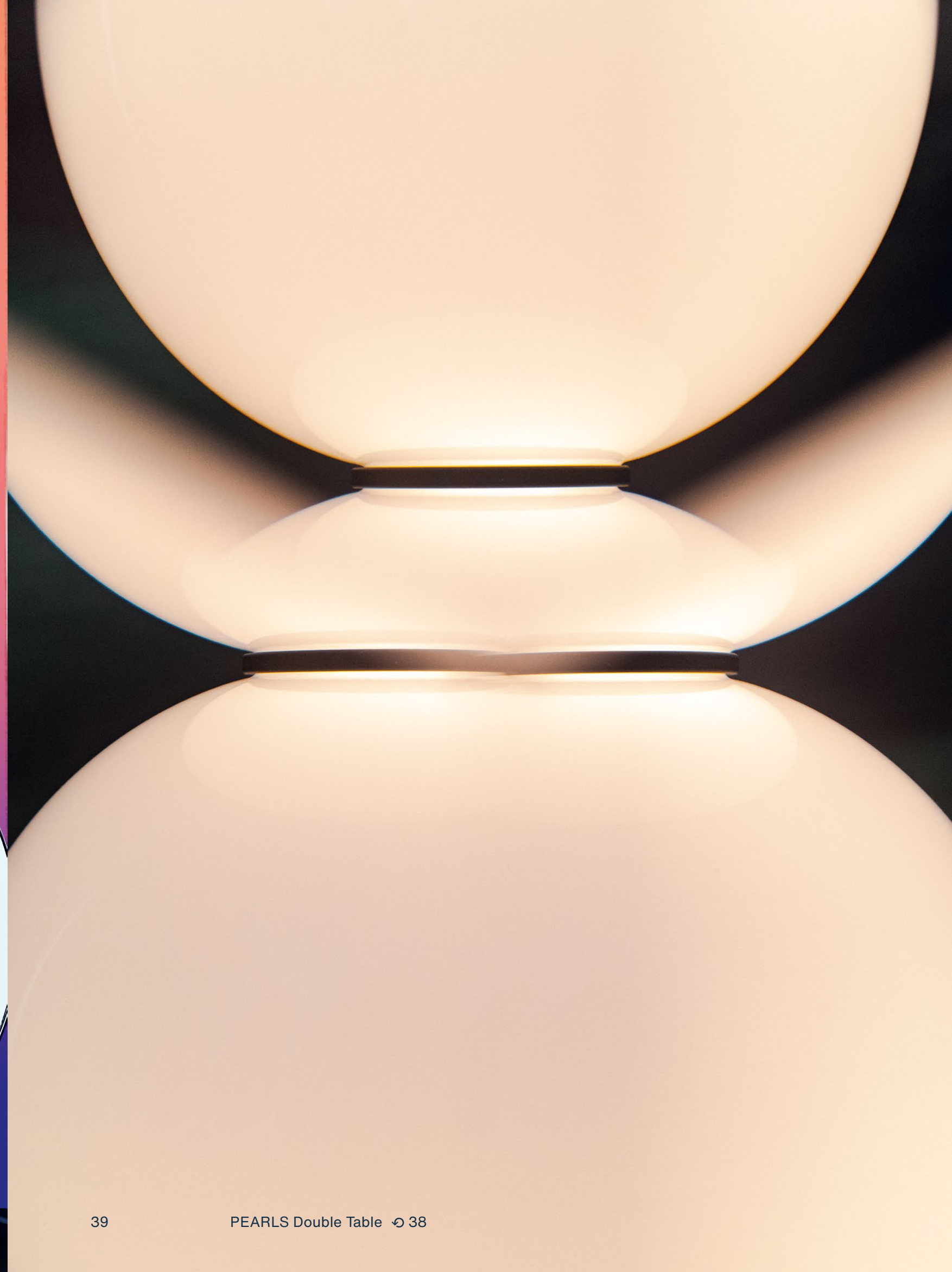

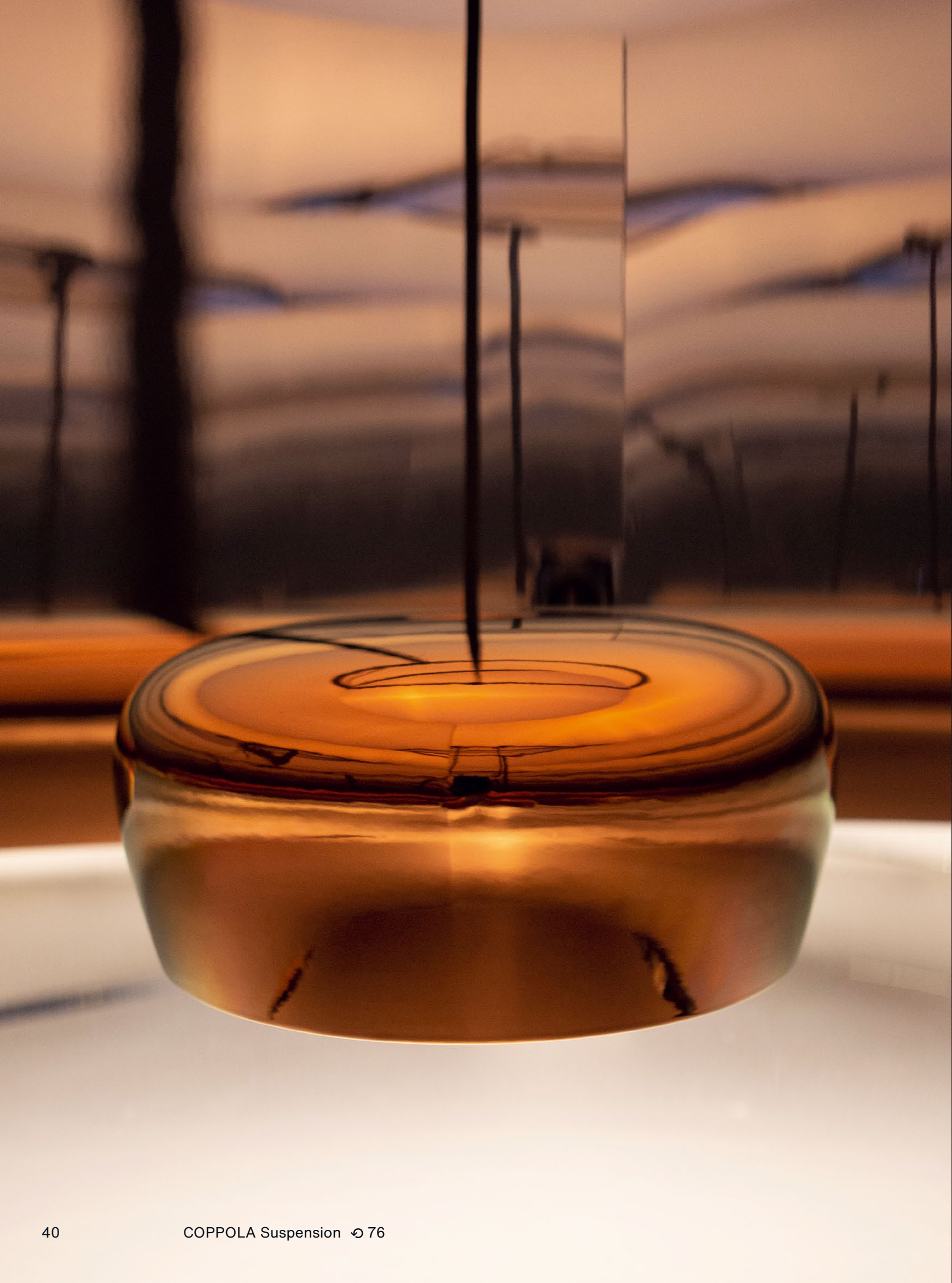

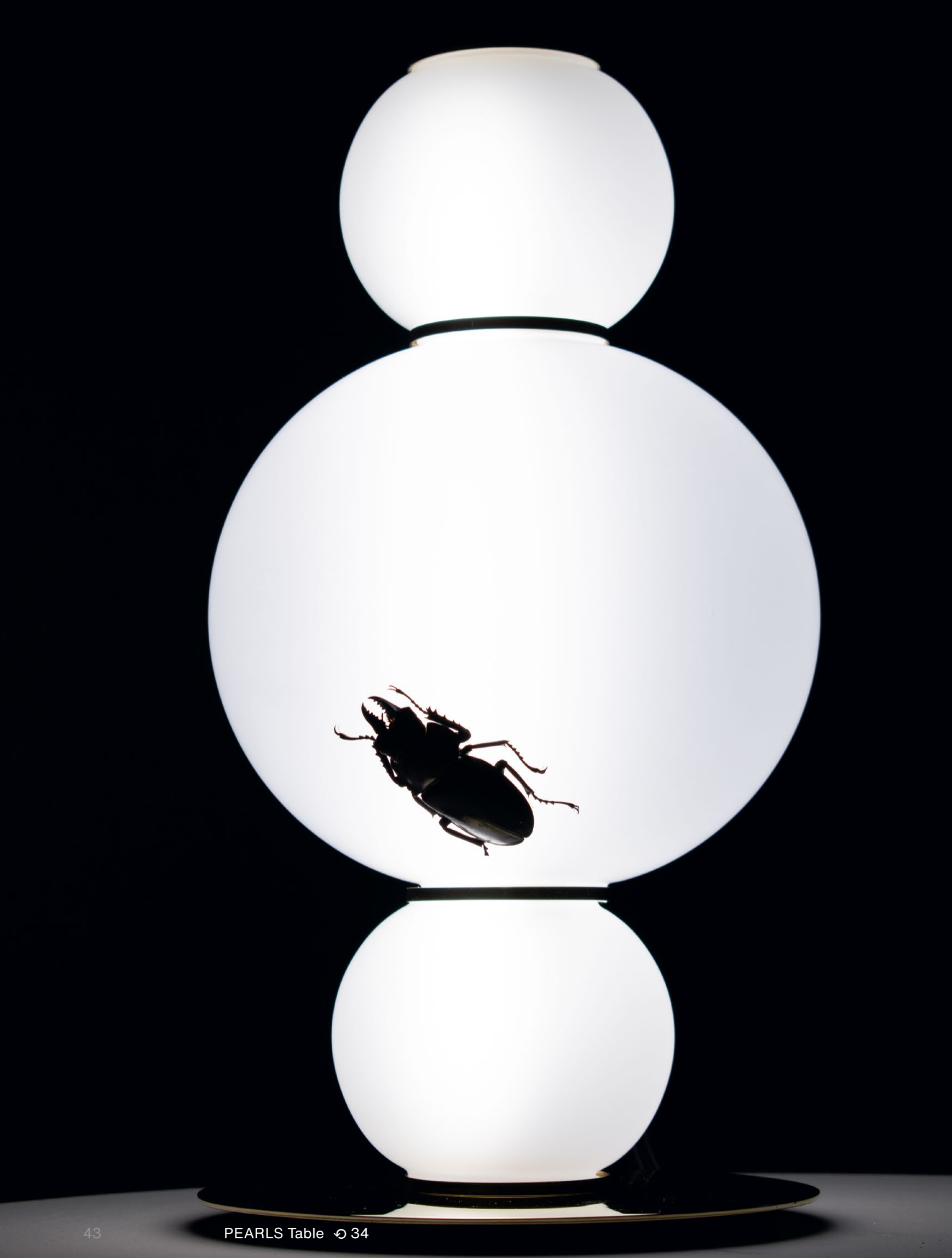





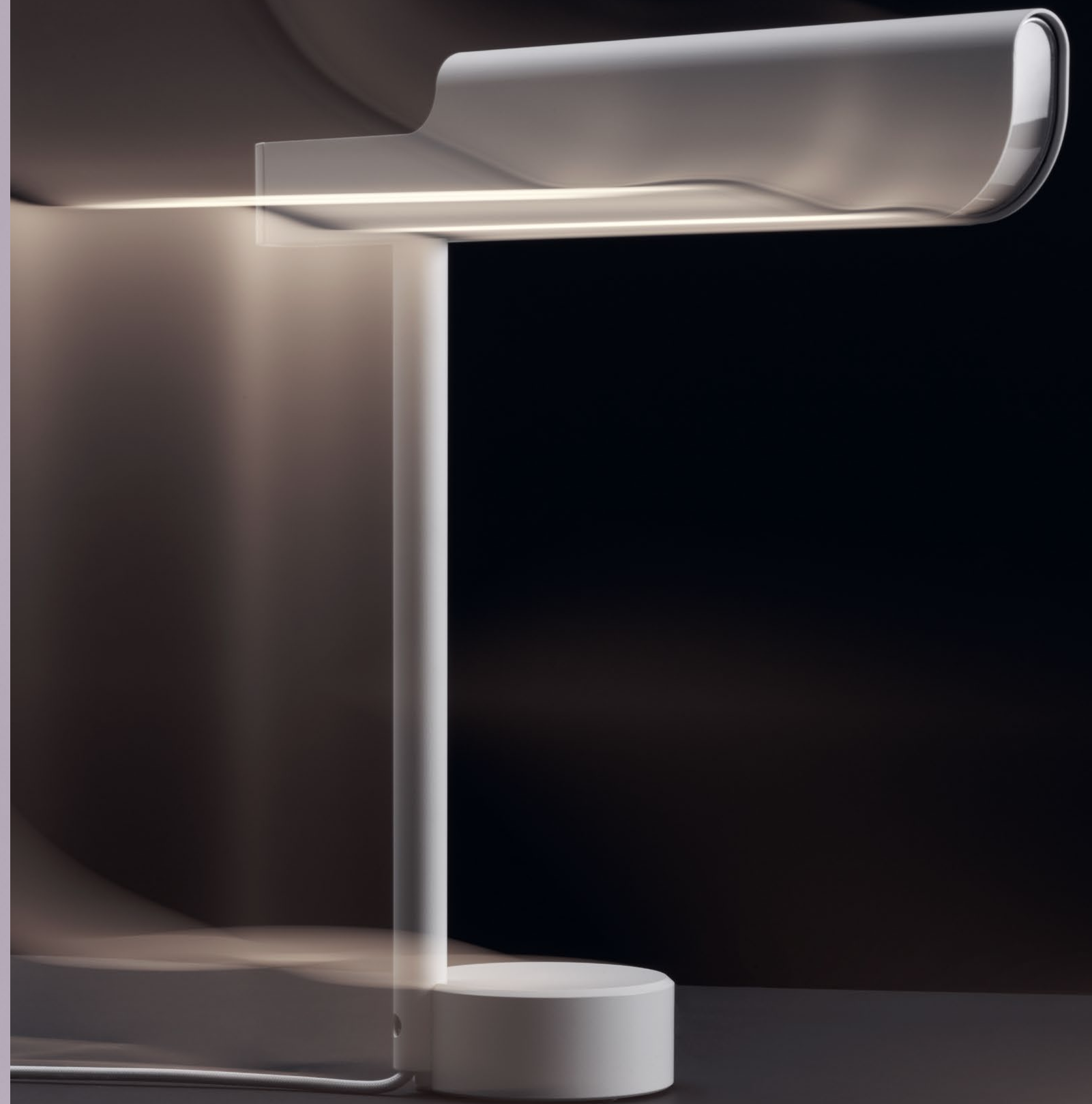

© 2022 FORMAGENDA GMBH  
THE NEW ENLIGHTENMENT

COPY  
Lukas Kubina

ART DIRECTION  
WIEGAND VON HARTMANN

PHOTOGRAPHY  
Aylin Langreuter  
Felix Brandl  
Gerhardt Kellermann  
Henning Bornemann  
Kaveh Kasravi  
Kilian Brees  
Manuel Nieberle  
SCHMOTT Studios  
Sonja Müller

TECHNISCHE UND FORMALE ÄNDERUNGEN VORBEHALTEN  
SUBJECT TO ALTERATION WITHOUT NOTICE

MÜNCHNER FREIHEIT 24  
80802 MÜNCHEN  
GERMANY

INFO@FORMAGENDA.COM  
+49 89 414240880  
WWW.FORMAGENDA.COM

## FORMAGENDA

FORMAGENDA is a lighting manufactory in Munich, Germany. The timeless products are processed on the highest level and are hand-finished to perfection. Through shape and light, FORMAGENDA's objects build long-lasting relationships with their environment. The subtle design language communicates emotions and creates cosy residential and clean professional atmospheres alike. Gentle associations and playful clarity merge in each object and add to FORMAGENDA's universe: THE NEW ENLIGHTENMENT.

**PRODUCTS**

10	PEARLS	Suspension
16		Double Suspension
20		Chandelier
26		Double Chandelier
30		Wall
34		Table
38		Double Table
44	PROFILE	Suspension 120
48		Floor Vertical
52		Floor Horizontal
56		Table 47
62	CHAPLIN	Table
66		Wall
70		Floor
76	COPPOLA	Suspension
80		Chandelier
84		Table
90	DON CAMILLO	Table
94		Wall
100	E.T.	Table
106	PEPPONE	Table
110		Wall
116	MIRROR	Small Suspension
120		Square Suspension
124		Wide Suspension



The PEARLS family provides classy solutions for every situation and space. By combining glass spheres in different sizes, various arrangements and shapes arise: compact pendant lamps, small or large scale chandeliers, table and wall lamps. The design options are countless—and multiple PEARLS are the ideal choice for consistent decor without redundancy.

- Holistic Product Range
- Abundant Elegance
- Geometric vs. Playful Combinations
- Consistent Design without Redundancy
- Bespoke Solutions for All Situations
- Mouth-Blown Glass Spheres
- Handcrafted to Perfection
- Design by Benjamin Hopf
- German Design Award, Design and Design Int. Award

# PEARLS

PEARLS Suspension

DESIGN  
MATERIAL  
FINISHES

Benjamin Hopf  
Glass, Brass  
Glossy Opal White or  
Transparent Frosted Matte Glass  
Metal Details in Polished Brass,  
Chrome Plated, Nickel Satin or Black Matte  
Fabric Covered Cable in Black or White

LIGHT SOURCE

2 x 4,4 W LED, 500 mA, ca. 1200 lm, CRI > 90  
Warm White 2700 K  
2200 K, 3000 K, 4000 K, 5000 K on Request  
Exchangeable LED-Modules  
Dimmable (Phase Cut), DALI on Request  
B

ENERGY EFFICIENCY

Overlength on Request

OTHER

Customized Large Scale Installations on Request

AWARDS

Design and Design International Award  
German Design Award 2017

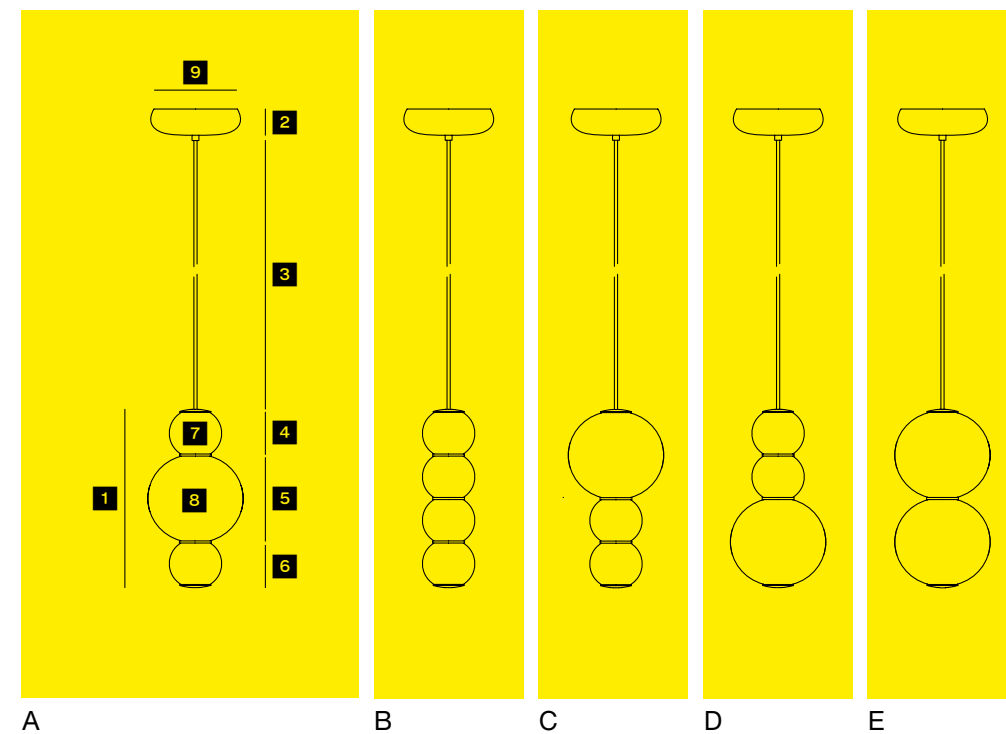

- 1 340 mm
- 2 50 mm
- 3 Max. 2500 mm  
Height Adjustable
- 4 80 mm
- 5 165 mm
- 6 80 mm
- 7 Ø 100 mm
- 8 Ø 180 mm
- 9 Ø 170 mm









PEARLS Double Suspension

DESIGN	Benjamin Hopf
MATERIAL	Glass, Brass
FINISHES	Glossy Opal White or Transparent Frosted Matte Glass Metal Details in Polished Brass, Chrome Plated, Nickel Satin or Black Matte
LIGHT SOURCE	Fabric Covered Cable in Black or White 4 x 4,4 W LED, 500 mA, ca. 2400 lm, CRI > 90 Warm White 2700 K 2200 K, 3000 K, 4000 K, 5000 K on Request Exchangeable LED-Modules Dimmable (Phase Cut), DALI on Request
ENERGY EFFICIENCY	B
OTHER	Overlength on Request Customized Large Scale Installations on Request
AWARDS	Design and Design International Award German Design Award 2017

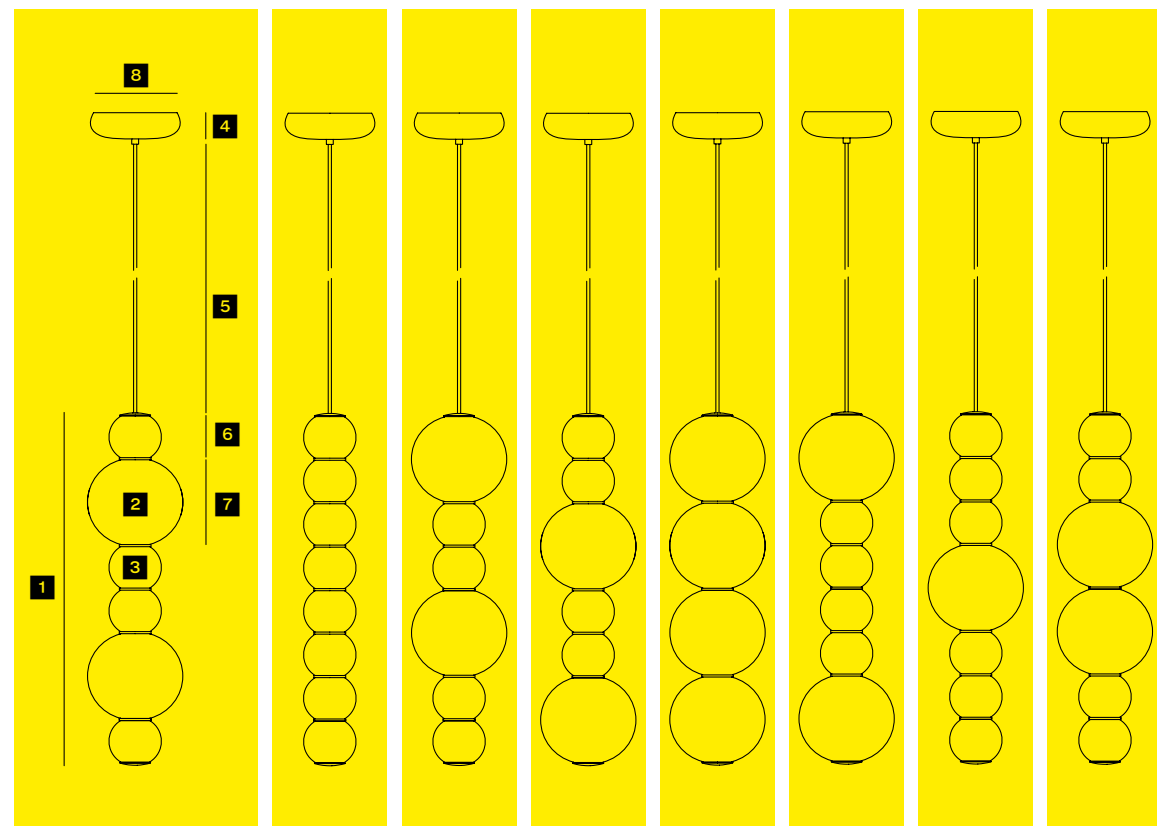

A

B

C

D

E

F

G

H

- 1** 670 mm
- 2** Ø 180 mm
- 3** Ø 100 mm
- 4** 50 mm
- 5** Max . 2500 mm  
Height Adjustable
- 6** 80 mm
- 7** 165 mm
- 8** Ø 170 mm





PEARLS Chandelier

DESIGN  
MATERIAL  
FINISHES

Benjamin Hopf  
Glass, Brass  
Glossy Opal White or  
Transparent Frosted Matte Glass  
Metal Details in Polished Brass,  
Chrome Plated, Nickel Satin or Black Matte  
Fabric Covered Cable in Black or White  
LIGHT SOURCE  
Each Unit 2 x 4,4 W LED, 500 mA, ca. 1200 lm, CRI > 90  
Warm White 2700 K  
2200 K, 3000 K, 4000 K, 5000 K on Request  
Exchangeable LED-Modules  
Dimmable (Phase Cut), DALI on Request  
ENERGY EFFICIENCY  
OTHER  
Overlength on Request  
Customized Large Scale Chandeliers on Request  
GROUPING  
AWARDS  
Choose Your Own Mix of Units A-E  
Design and Design International Award  
German Design Award 2017

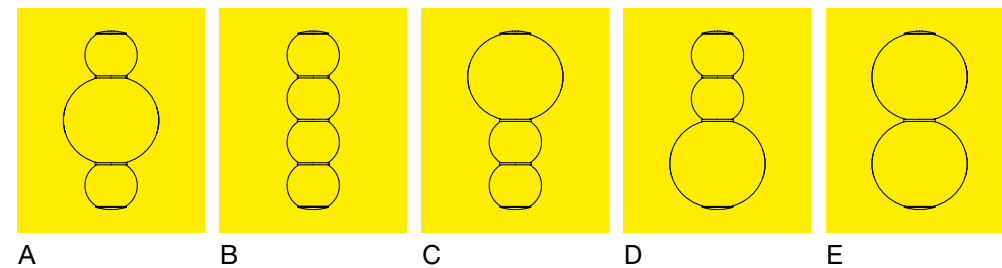
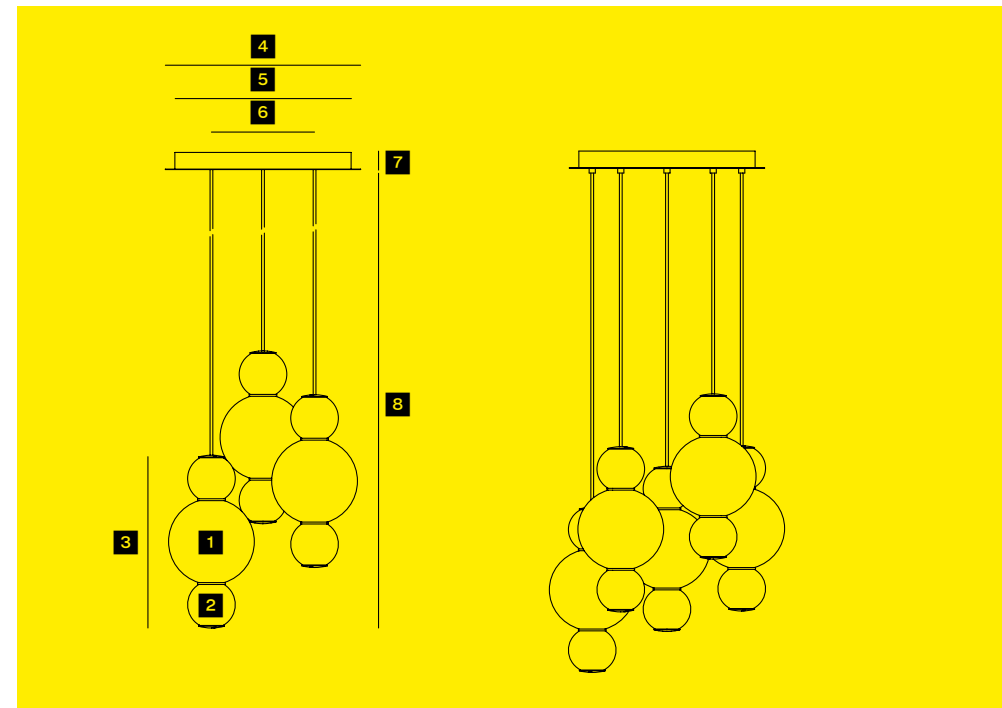

- 1 Ø 180 mm
- 2 Ø 100 mm
- 3 340 mm
- 4 410 mm
- 5 370 mm
- 6 315 mm
- 7 50 mm
- 8 Max. 2500 mm  
Height Adjustable







PEARLS Double Chandelier

DESIGN  
MATERIAL  
FINISHES

Benjamin Hopf  
Glass, Brass  
Glossy Opal White or  
Transparent Frosted Matte Glass  
Metal Details in Polished Brass,  
Chrome Plated, Nickel Satin or Black Matte  
Fabric Covered Cable in Black or White  
LIGHT SOURCE  
Each Unit 4 × 4,4 W LED, 500 mA, ca. 2400 lm, CRI > 90  
Warm White 2700 K  
2200 K, 3000 K, 4000 K, 5000 K on Request  
Exchangeable LED-Modules  
Dimmable (Phase Cut), DALI on Request  
ENERGY EFFICIENCY  
B  
OTHER  
Overlength on Request  
Customized Large Scale Chandeliers on Request  
GROUPING  
Choose Your Own Mix of Units A–H  
AWARDS  
Design and Design International Award  
German Design Award 2017

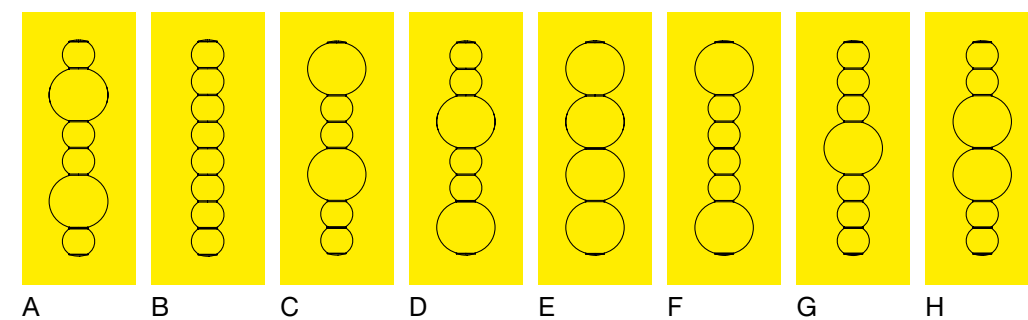
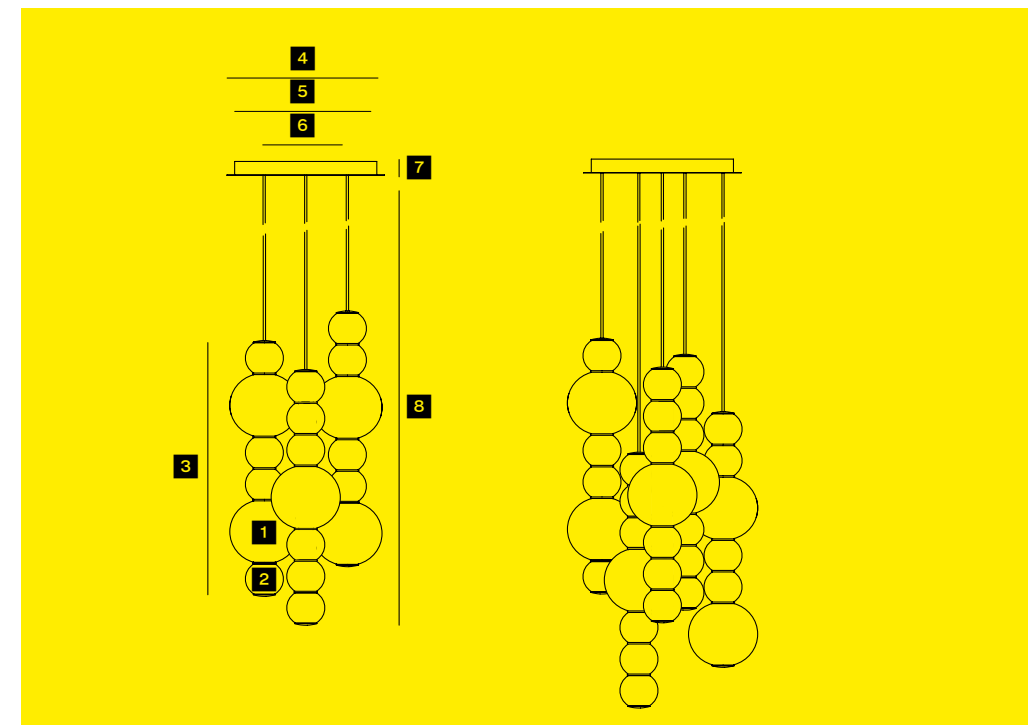

- 1 Ø 180 mm
- 2 Ø 100 mm
- 3 670 mm
- 4 410 mm
- 5 370 mm
- 6 216 mm
- 7 45 mm
- 8 Max. 2500 mm  
Height Adjustable

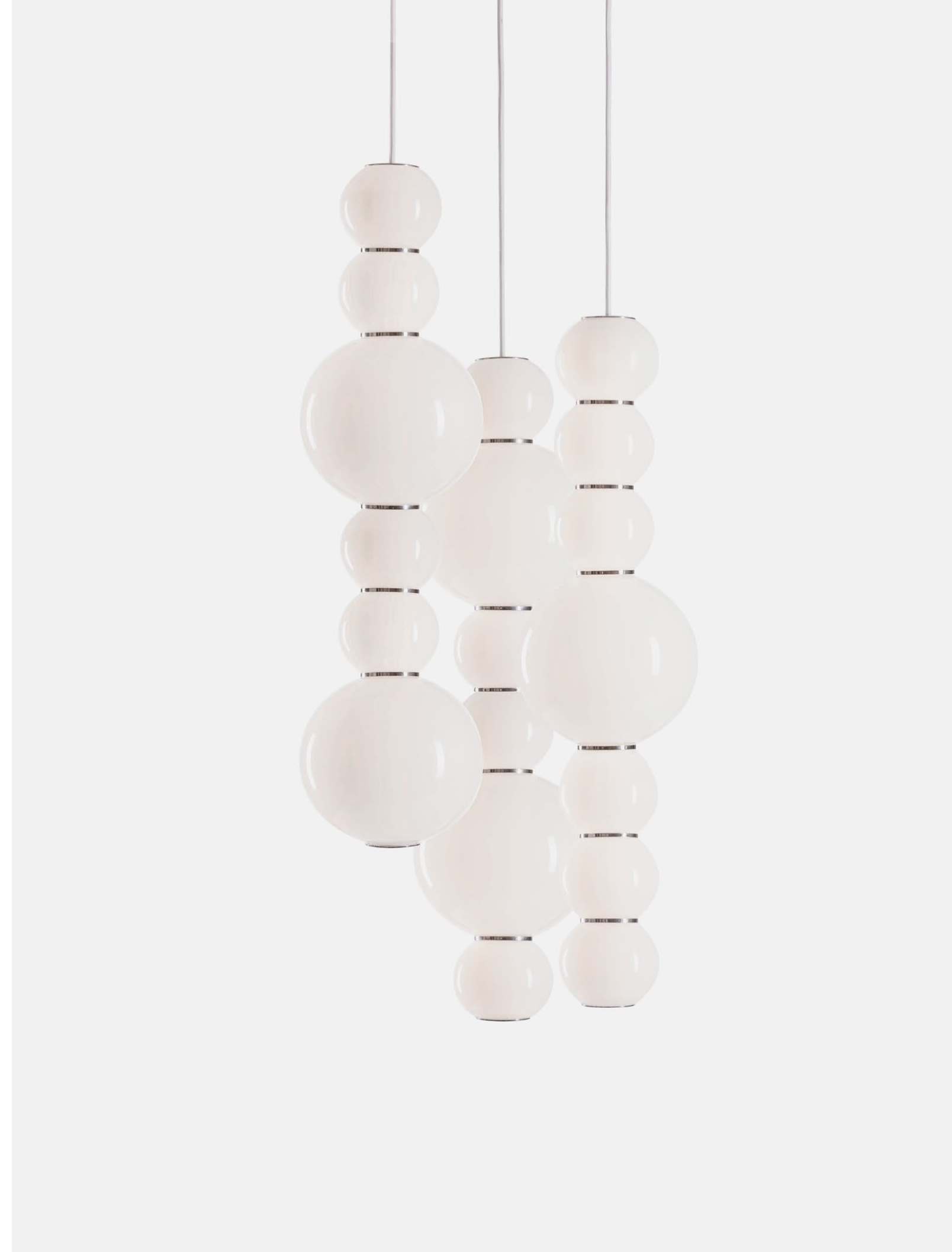



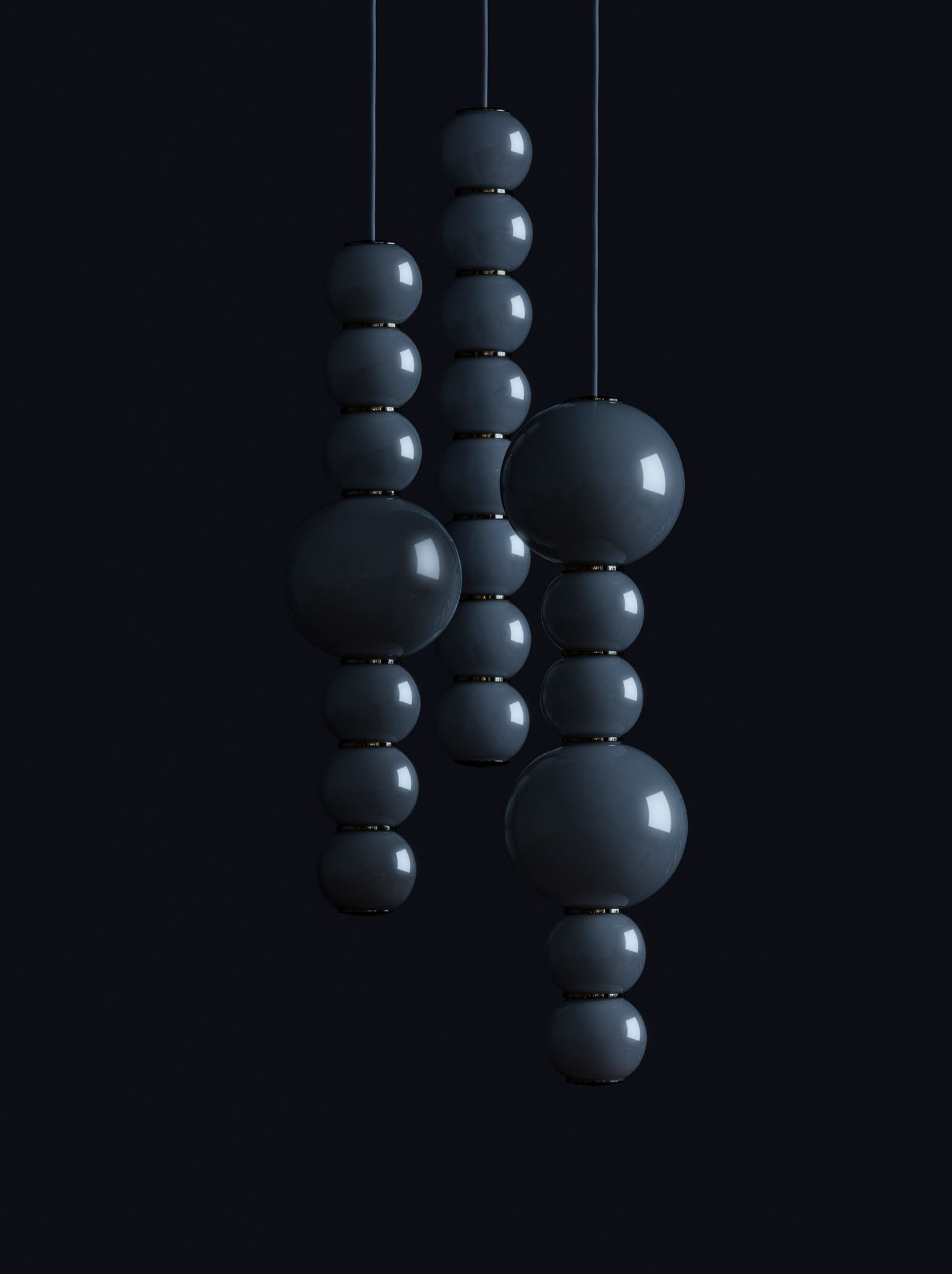

PEARLS Wall

DESIGN  
MATERIAL  
FINISHES

Benjamin Hopf  
Glass, Brass  
Glossy Opal White or  
Transparent Frosted Matte Glass  
Metal Details in Polished Brass or Chrome Plated

LIGHT SOURCE  
2 x 4,4 W LED, 500 mA, ca. 1200 lm, CRI > 90  
Warm White 2700 K  
2200 K, 3000 K, 4000 K, 5000 K on Request  
Exchangeable LED-Modules  
Dimmable

ENERGY EFFICIENCY  
AWARDS  
B  
Design and Design International Award  
German Design Award 2017

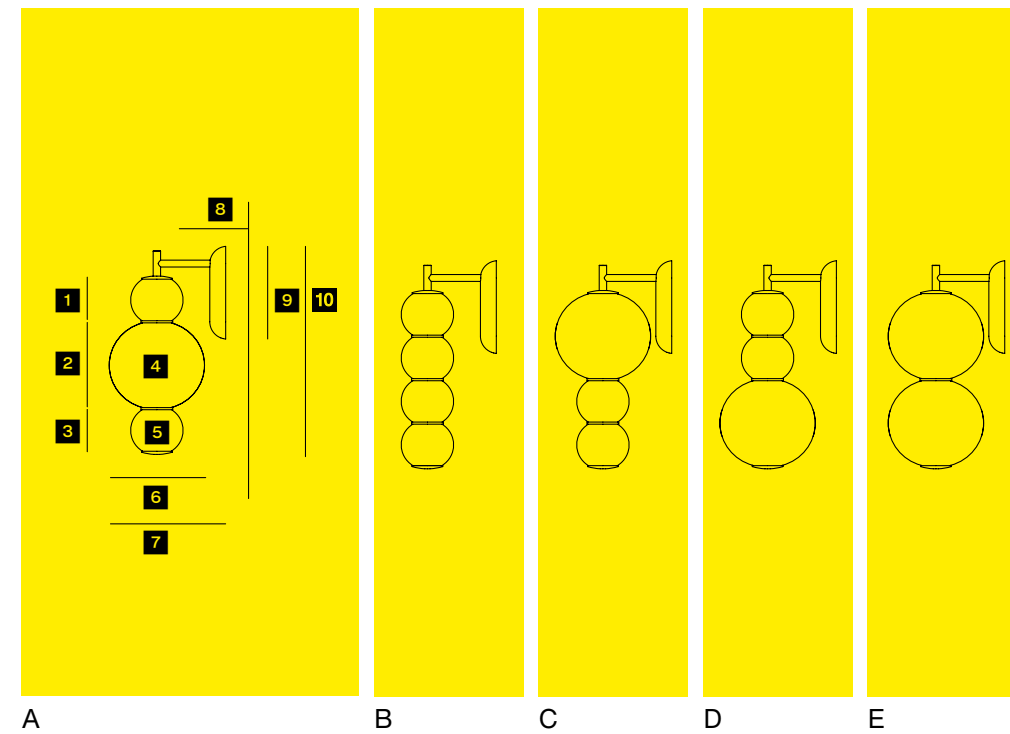



PEARLS Table

DESIGN  
MATERIAL  
FINISHES

Benjamin Hopf  
Glass, Brass  
Glossy Opal White or  
Transparent Frosted Matte Glass  
Metal Details in Polished Brass,  
Chrome Plated or Black Matte  
Fabric Covered Cable in Black  
LIGHT SOURCE  
2 x 3,2 W LED, 350 mA, ca. 800 lm, CRI > 90  
Warm White 2700 K  
2200 K, 3000 K, 4000 K, 5000 K on Request  
Exchangeable LED-Modules  
Dimmable  
ENERGY EFFICIENCY  
C  
AWARDS  
Design and Design International Award  
German Design Award 2017

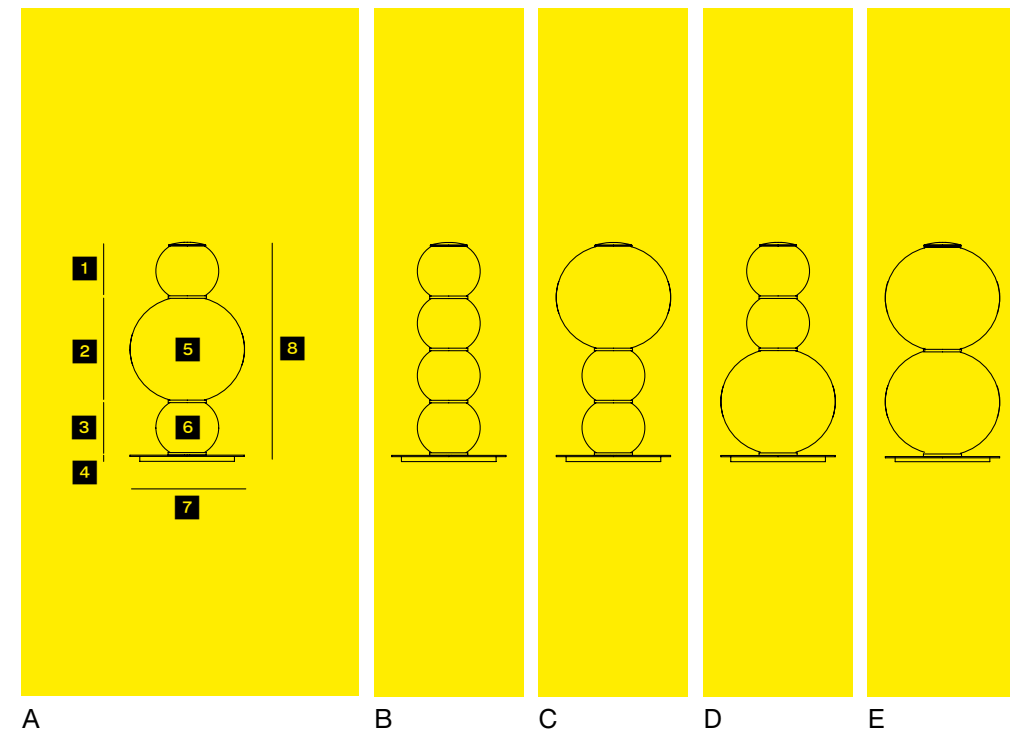

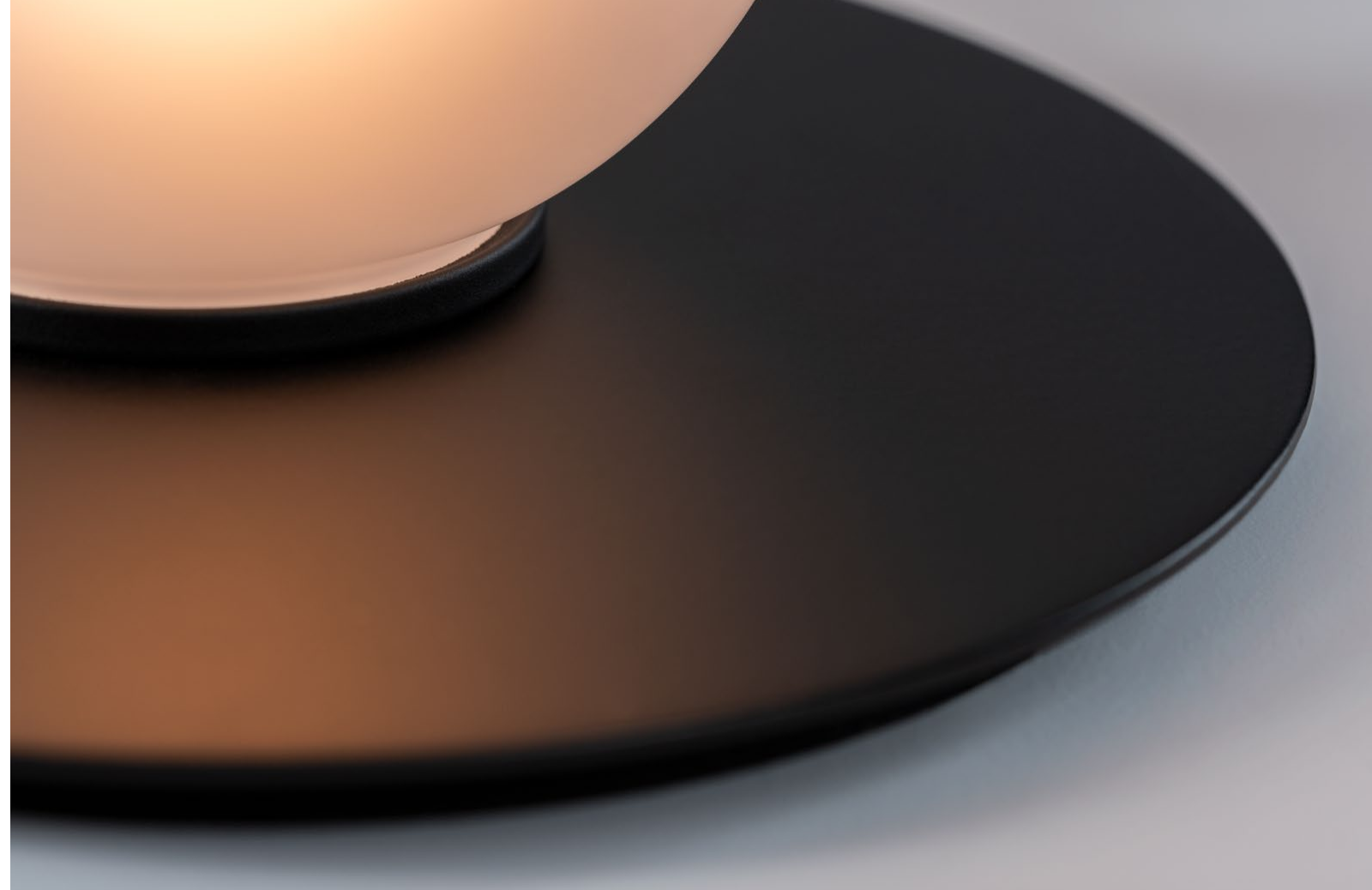

PEARLS Double Table

DESIGN  
MATERIAL  
FINISHES

Benjamin Hopf  
Glass, Brass  
Glossy Opal White or  
Transparent Frosted Matte Glass  
Metal Details in Polished Brass,  
Chrome Plated, Nickel Satin or Black Matte  
Fabric Covered Cable in Black or White  
LIGHT SOURCE  
4 × 4,4 W LED, 500 mA, ca. 1200 lm, CRI > 90  
Warm White 2700 K  
2200 K, 3000 K, 4000 K, 5000 K on Request  
Exchangeable LED-Modules  
Dimmable  
ENERGY EFFICIENCY  
B  
AWARDS  
Design and Design International Award  
German Design Award 2017

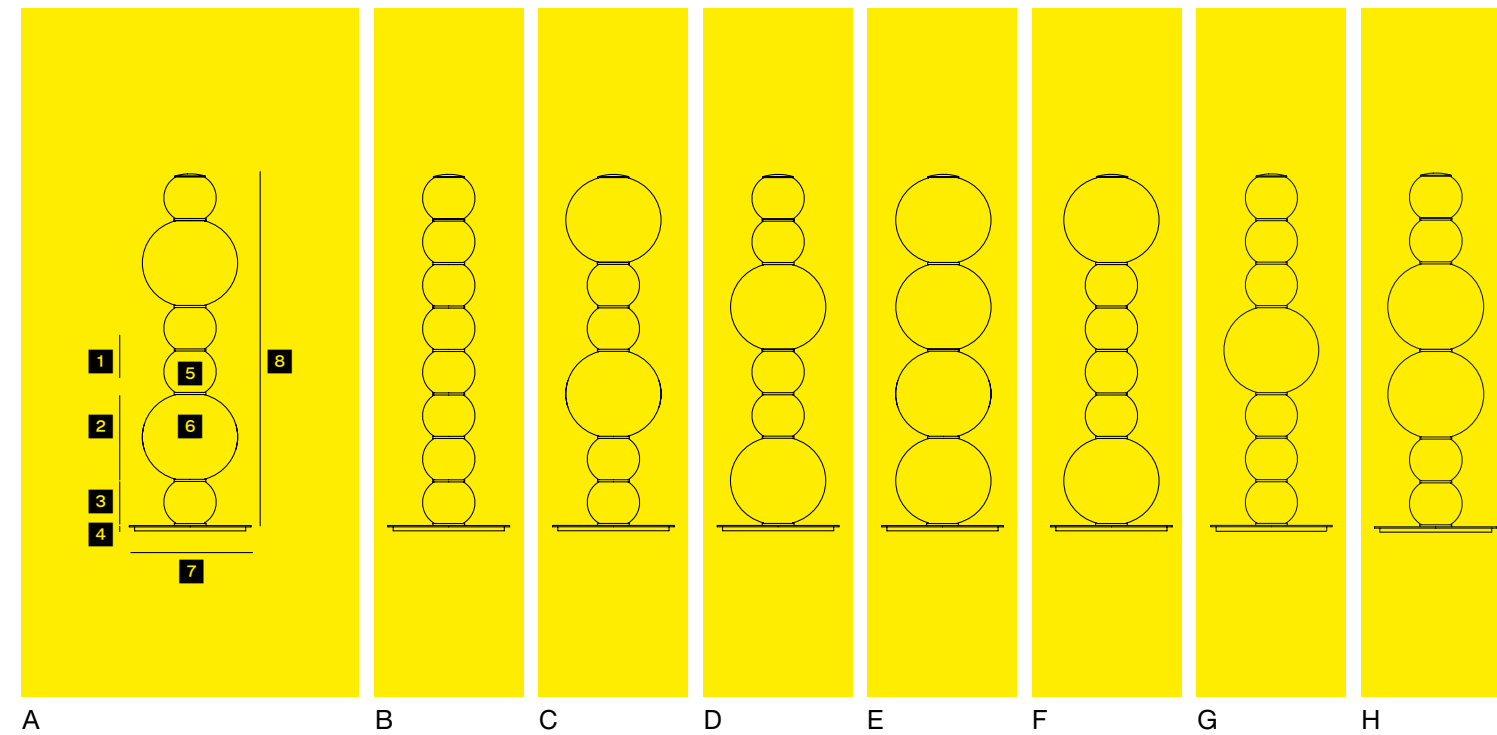

- 1 380 mm
- 2 165 mm
- 3 80 mm
- 4 10 mm
- 5 Ø 100 mm
- 6 Ø 180 mm
- 7 230 mm
- 8 670 mm







The name speaks for itself. Concise contours and minimalistic design create a linear lighting concept. The PROFILE luminaire family is available in four different outfits: sturdy powder coating, elegant woolen fabric, Alcantara or fine vegan leather cover—and finishes or covers can be customized to suit any project.

- Linear Lighting Concept
- State of the Art Technology
- Versatile Surface Choices
- Customization / Branding Possibilities
- Reduced Design Language and Playful Clarity
- Maximum Diversity for Every Design Need
- Destined for Residential and Professional Spaces
- Design by Christophe de la Fontaine
- Focus Open Award

# PROFILE



PROFILE Suspension 120

DESIGN	Christophe de la Fontaine
MATERIAL	Aluminium
FINISHES	Powdercoated Black Matte or White Matte, Alcantara in Various Colours, Vegan Leather in Various Colours, Woolen Fabric in Various Colours
LIGHT SOURCE	LED 25,2 W, 2900 lm, CRI > 90 Warm White 2700 K Dimmable (Various Options) Exchangeable LED Modules 2200 K, 3000 K, 4000 K, 5000 K on Request
ENERGY EFFICIENCY	B
OPTIONS	Dim to Warm 2200/2700 K DALI Custom Finishes or Covers on Request Overlength on Request
AWARDS	Focus Open Award 2020 German Design Award 2022

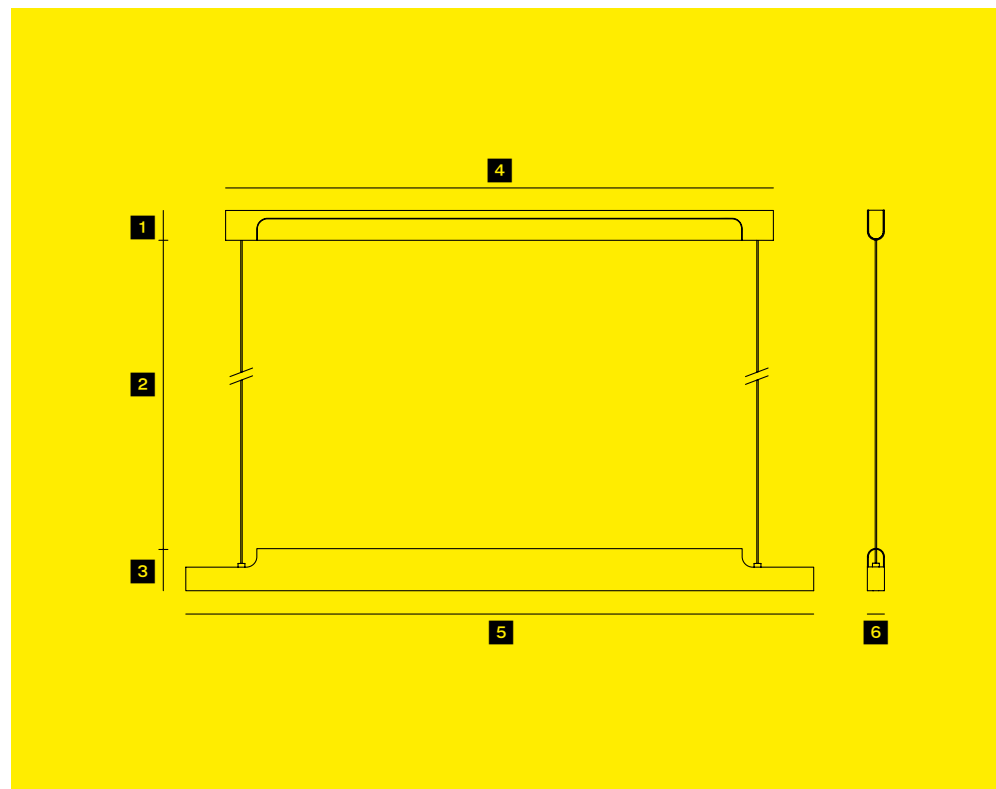

- 1 55 mm
- 2 Max . 2000 mm  
Height Adjustable
- 3 80 mm
- 4 1030 mm
- 5 1200 mm
- 6 32 mm



PROFILE Floor Vertical

DESIGN  
MATERIAL  
FINISHES

Christophe de la Fontaine  
Aluminium  
Powdercoated Black Matte or White Matte,  
Alcantara in Various Colours,  
Vegan Leather in Various Colours,  
Woolen Fabric in Various Colours  
LED 25,2 W, 2900 lm, CRI > 90,  
Warm White 2700 K  
Dimmable  
Exchangeable LED Modules  
B  
Dim to Warm 2200/2700 K  
2200 K, 3000 K, 4000 K, 5000 K on Request  
Custom Finishes or Covers on Request  
Cord Dimmer  
Focus Open Award 2020  
German Design Award 2022

LIGHT SOURCE

ENERGY EFFICIENCY  
OPTIONS

OTHER  
AWARDS

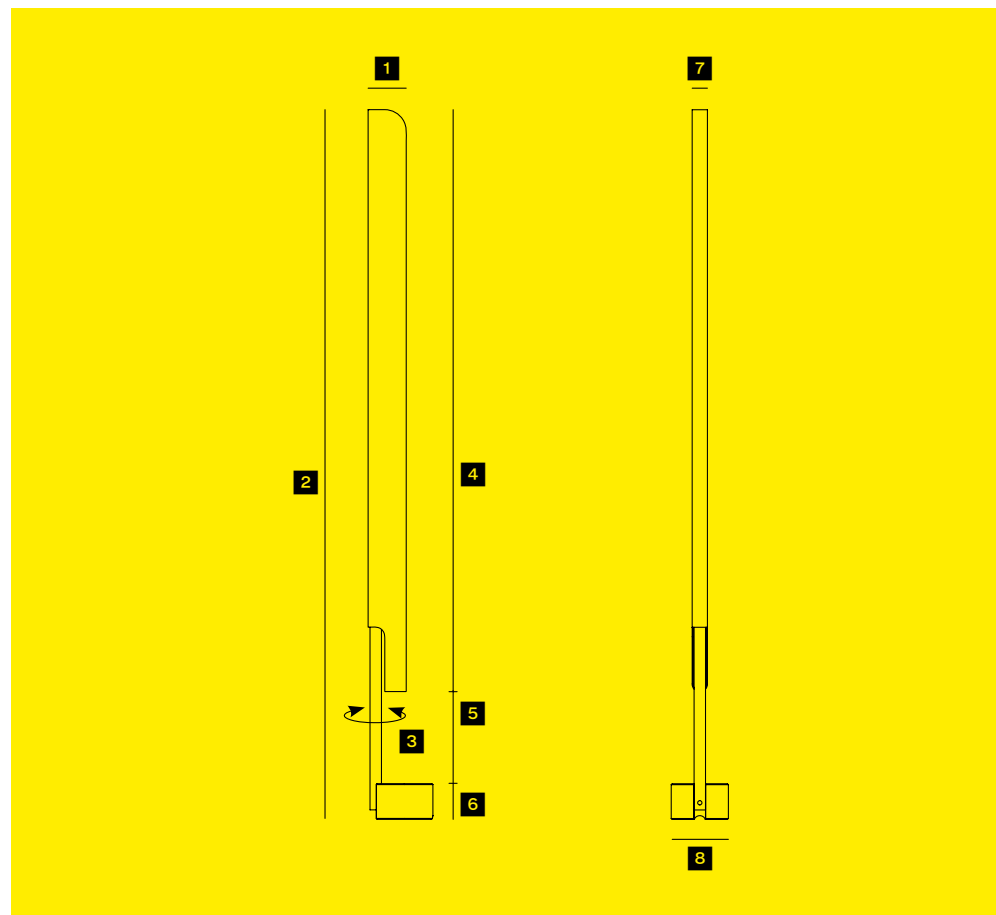

- 1 80 mm
- 2 1490 mm
- 3 350°
- 4 1220 mm
- 5 195 mm
- 6 75 mm
- 7 32 mm
- 8 120 mm

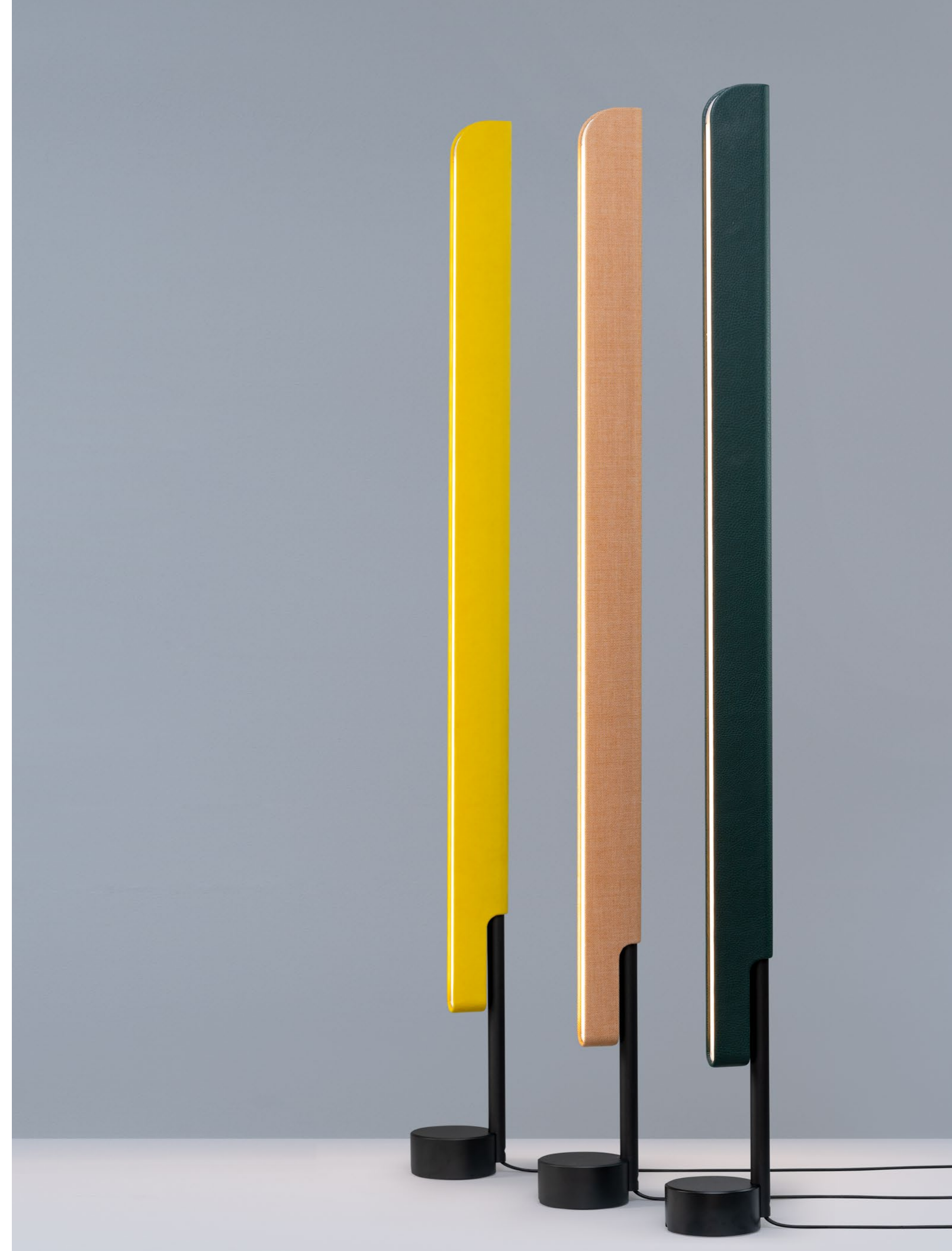



PROFILE Floor Horizontal

DESIGN	Christophe de la Fontaine
MATERIAL	Aluminium
FINISHES	Powdercoated Black Matte or White Matte, Alcantara in Various Colours, Vegan Leather in Various Colours, Woolen Fabric in Various Colours
LIGHT SOURCE	LED 6,3 W, 800 lm, CRI > 90, Warm White 2700 K Dimmable
OPTIONS	Exchangeable LED Modules Dim to Warm 2200/2700 K 2200 K, 3000 K, 4000 K, 5000 K on Request
OTHER AWARDS	Custom Finishes or Covers on Request Focus Open Award 2020 German Design Award 2022

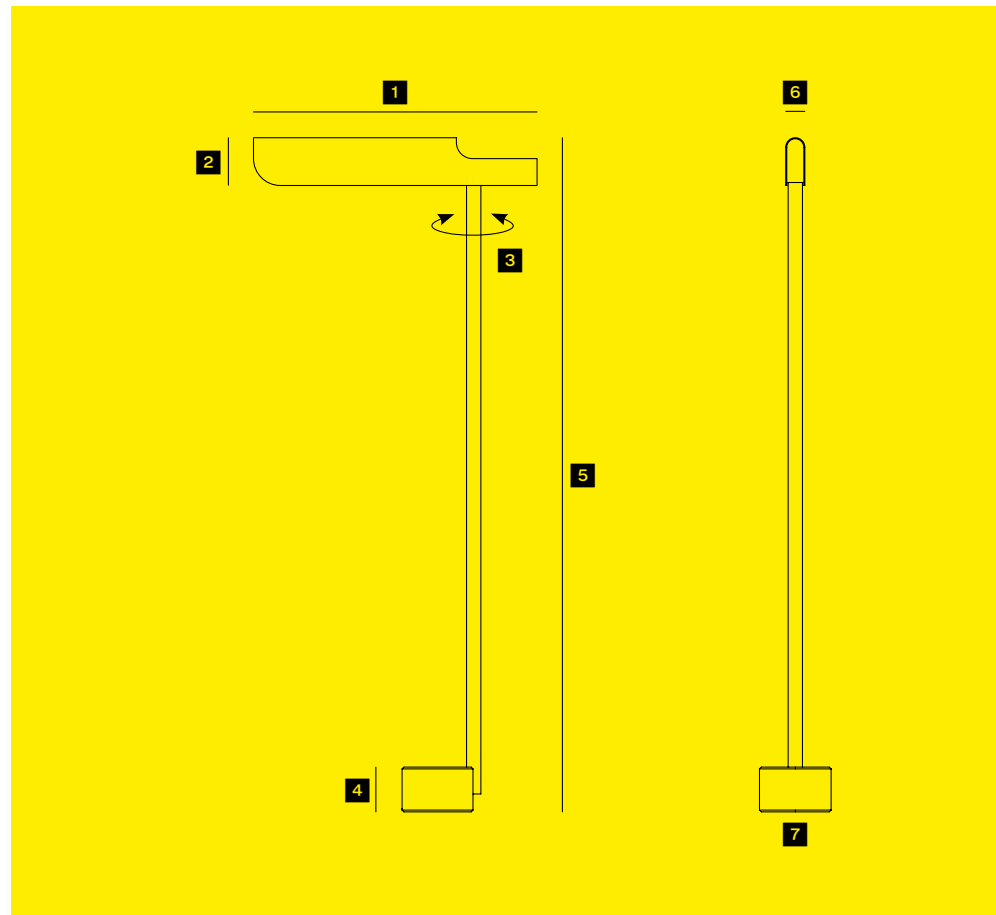

- 1 475 mm
- 2 80 mm
- 3 350°
- 4 75 mm
- 5 1130 mm
- 6 32 mm
- 7 120 mm





DESIGN	Christophe de la Fontaine
MATERIAL	Aluminium
FINISHES	Powdercoated Black Matte or White Matte, Alcantara in Various Colours, Vegan Leather in Various Colours, Woolen-Fabric in Various Colours
LIGHT SOURCE	LED 6,3W, 800 lm, CRI > 90, Warm White 2700 K Dimmable Exchangeable LED Modules 2200 K, 3000 K, 4000 K, 5000 K on Request
ENERGY EFFICIENCY	B
OPTIONS	Table Mounted Version Dim to Warm 2200/2700 K Custom Finishes or Covers on Request
AWARDS	Focus Open Award 2020 German Design Award 2022

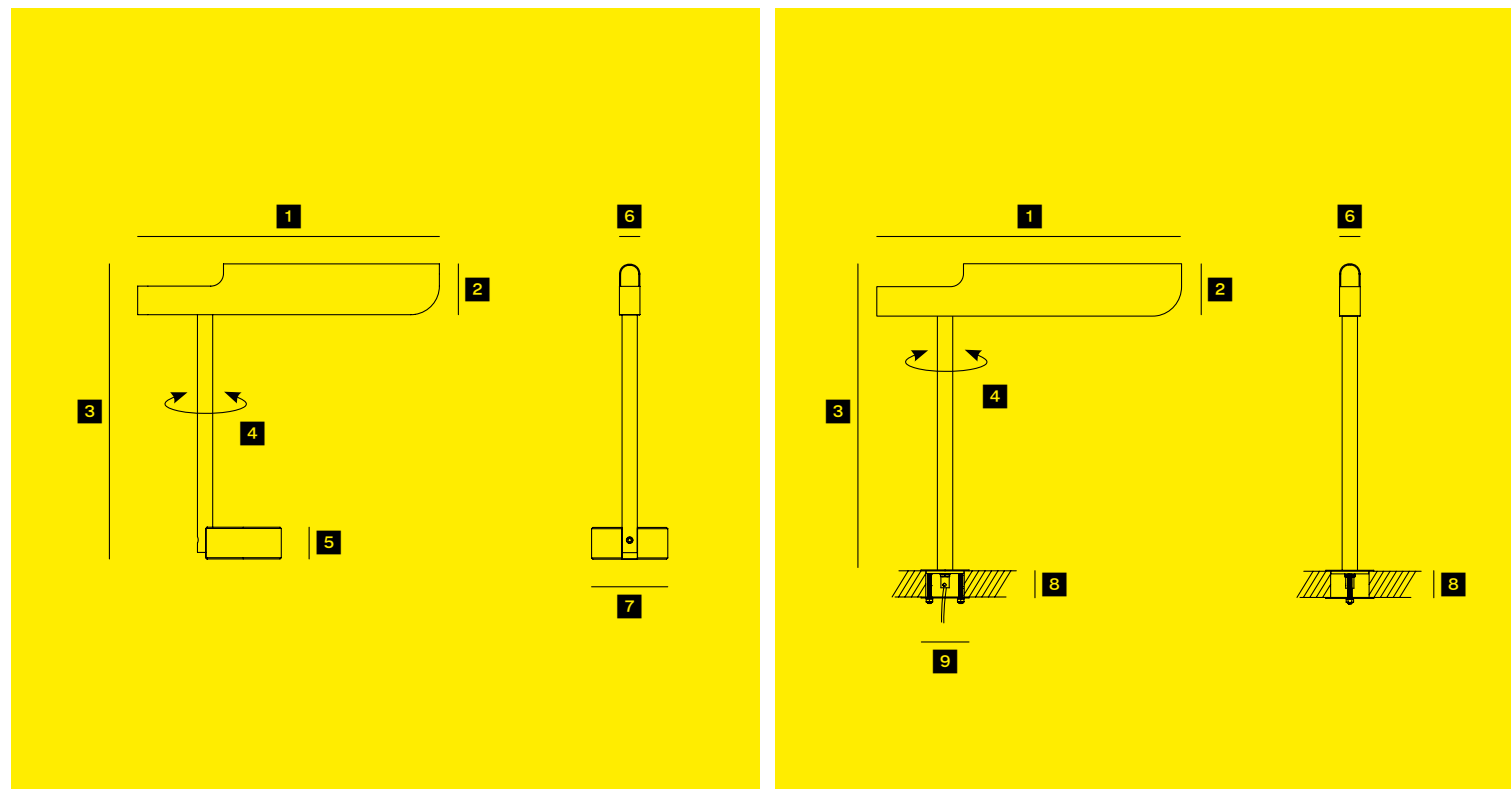

- 1** 475 mm
- 2** 80 mm
- 3** 465 mm
- 4** 350°
- 5** 50 mm
- 6** 32 mm
- 7** 120 mm
- 8** 20-40 mm
- 9** 60 mm









The charismatic CHAPLIN family articulates itself in minimal gestures. The refined head can be positioned as you like while the structure provides a solid simplicity. CHAPLIN generates an easy-going consistency if you place several pieces in a professional line-up.

- Solid Simplicity
- Iconic Form Language
- Charismatic Understatement
- Minimal Gestures
- Refined Head Turns and Rotates
- Destined for Residential and Professional Spaces
- Design by Benjamin Hopf
- German Design Award

# CHAPLIN

CHAPLIN Table

DESIGN	Benjamin Hopf
MATERIAL	Aluminium, Steel
FINISHES	Black Matte, White Matte
LIGHT SOURCE	Standard: LED 4,3 W, 500 mA, ca. 550 lm, CRI > 90, Warm White 2700 K Dimmable: LED 6,3 W, 700 mA, ca. 750 lm, CRI > 90, Warm White 2700 K
ENERGY EFFICIENCY	B
OTHER	Transparent Cable with Cord Switch Dimmable Version with Fabric Covered Cable and Touch Dimmer Plug-In Transformer
AWARDS	Design and Design International Award German Design Award 2017

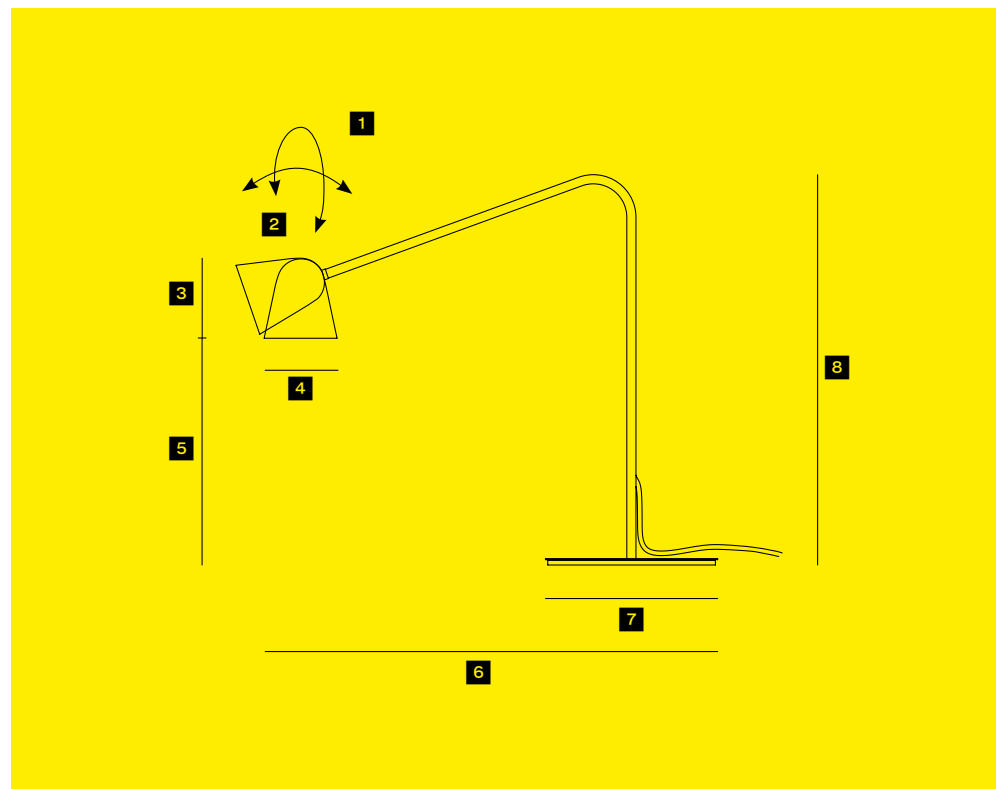

- 1 350°
- 2 90°
- 3 105 mm
- 4 95 mm
- 5 320 mm
- 6 600 mm
- 7 210 mm
- 8 520 mm





CHAPLIN Wall

DESIGN	Benjamin Hopf
MATERIAL	Aluminium, Steel
FINISHES	Black Matte, White Matte
LIGHT SOURCE	Standard: LED 4,3 W, 500 mA, ca. 550 lm, CRI > 90, Warm White 2700 K Dimmable: LED 6,3 W, 700 mA, ca. 750 lm, CRI > 90, Warm White 2700 K
ENERGY EFFICIENCY	B
OTHER	Transparent Cable with Cord Switch Dimmable Version with Fabric Covered Cable and Touch Dimmer Plug-In Transformer
AWARDS	Design and Design International Award German Design Award 2017

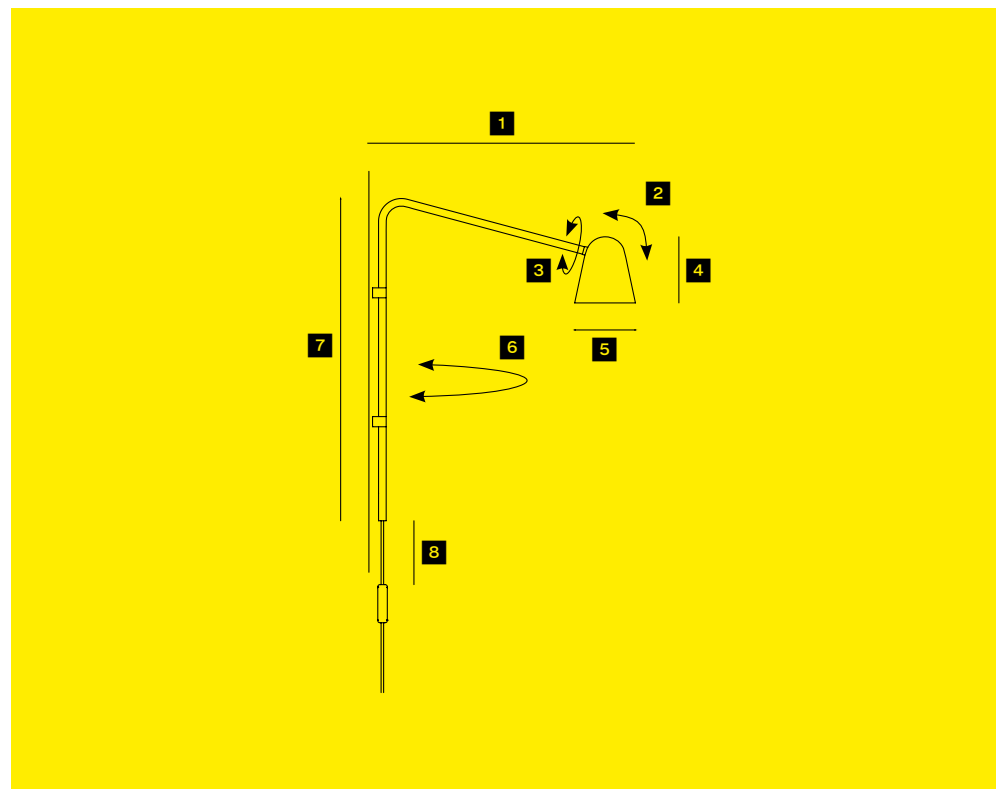

- 1 420 mm
- 2 90°
- 3 350°
- 4 105 mm
- 5 95 mm
- 6 180°
- 7 500 mm
- 8 100 mm





CHAPLIN Floor

DESIGN  
MATERIAL  
FINISHES  
LIGHT SOURCE  
ENERGY EFFICIENCY  
OTHER

Benjamin Hopf  
Aluminium, Steel  
Black Matte, White Matte  
LED 6,3 W, 700 mA, ca. 750 lm,  
CRI > 90, Warm White 2700 K  
B  
Fabric Covered Cable  
Plug-In Transformer  
Touch Dimmer

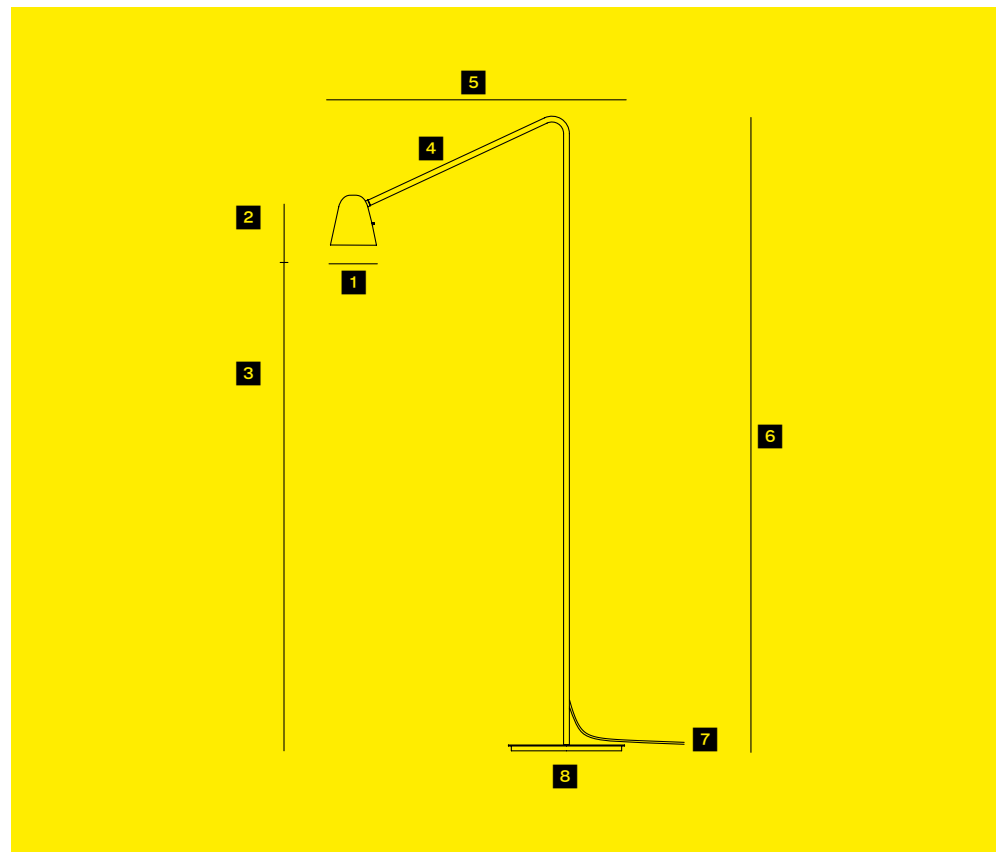

- 1 95 mm
- 2 105 mm
- 3 1050 mm
- 4 490 mm
- 5 605 mm
- 6 1300 mm
- 7 12 mm
- 8 240 mm







COPPOLA is an instant classic. The sophisticated design and high-value ceramics combine functionality with love for detail. Handcrafted to perfection, COPPOLA offers a brilliant touch of extravaganza.

- High-Value Ceramics
- Handcrafted to Perfection
- Sophisticated Design
- Love for Detail
- Shade Rotates on the Bulb
- Design by Christophe de la Fontaine

# COPPOLA



COPPOLA Suspension

DESIGN  
MATERIAL  
FINISHES

Christophe de la Fontaine  
Ceramics  
White, White with Golden Reflector,  
Light Grey, Rose, Petrol with  
White Reflector, Black with  
Golden Reflector, Black with  
White Reflector, Gold with  
White Reflector, Copper with  
White Reflector, Platinum with  
White Reflector

LIGHT SOURCE

Fabric Covered Cable  
3,8 W LED, 700 mA, ca. 670 lm,  
CRI > 90, Warm White 2700 K  
Dimmable (Phase Cut)

ENERGY EFFICIENCY  
OTHER

A  
Shade Rotatable  
Special Colors and Overlength on Request  
Canopy also available in White on Request  
White Fabric Covered Cable available on Request

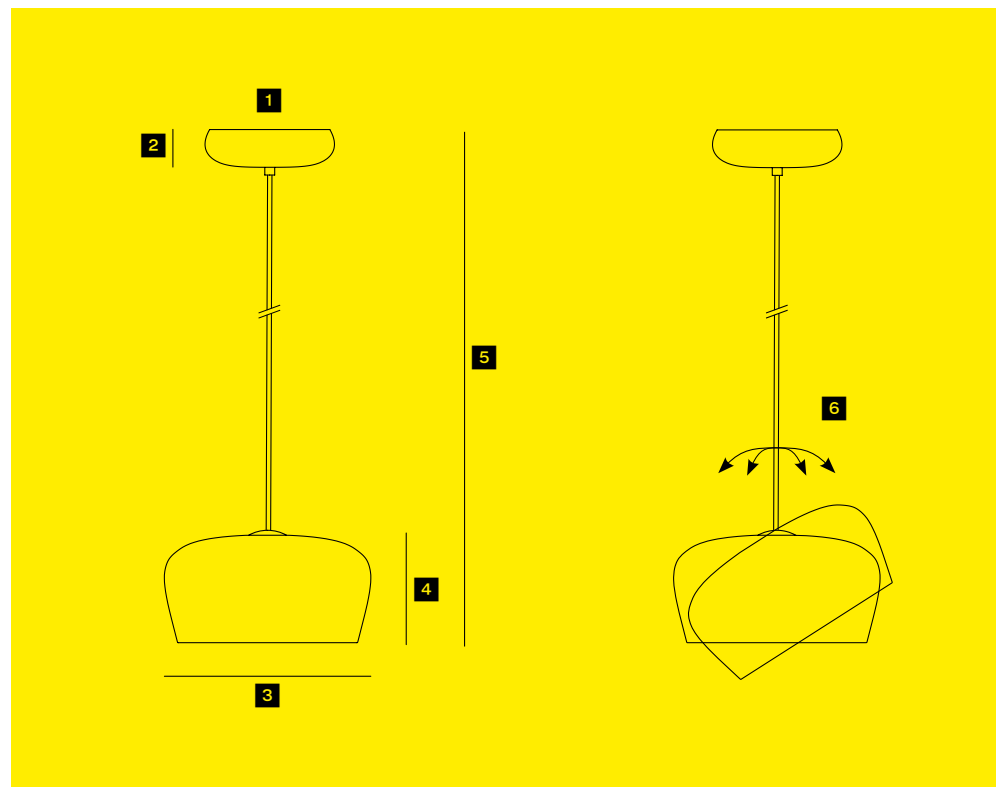

- 1 170 mm
- 2 50 mm
- 3 270 mm
- 4 140 mm
- 5 Max . 2500 mm
- 6 60°

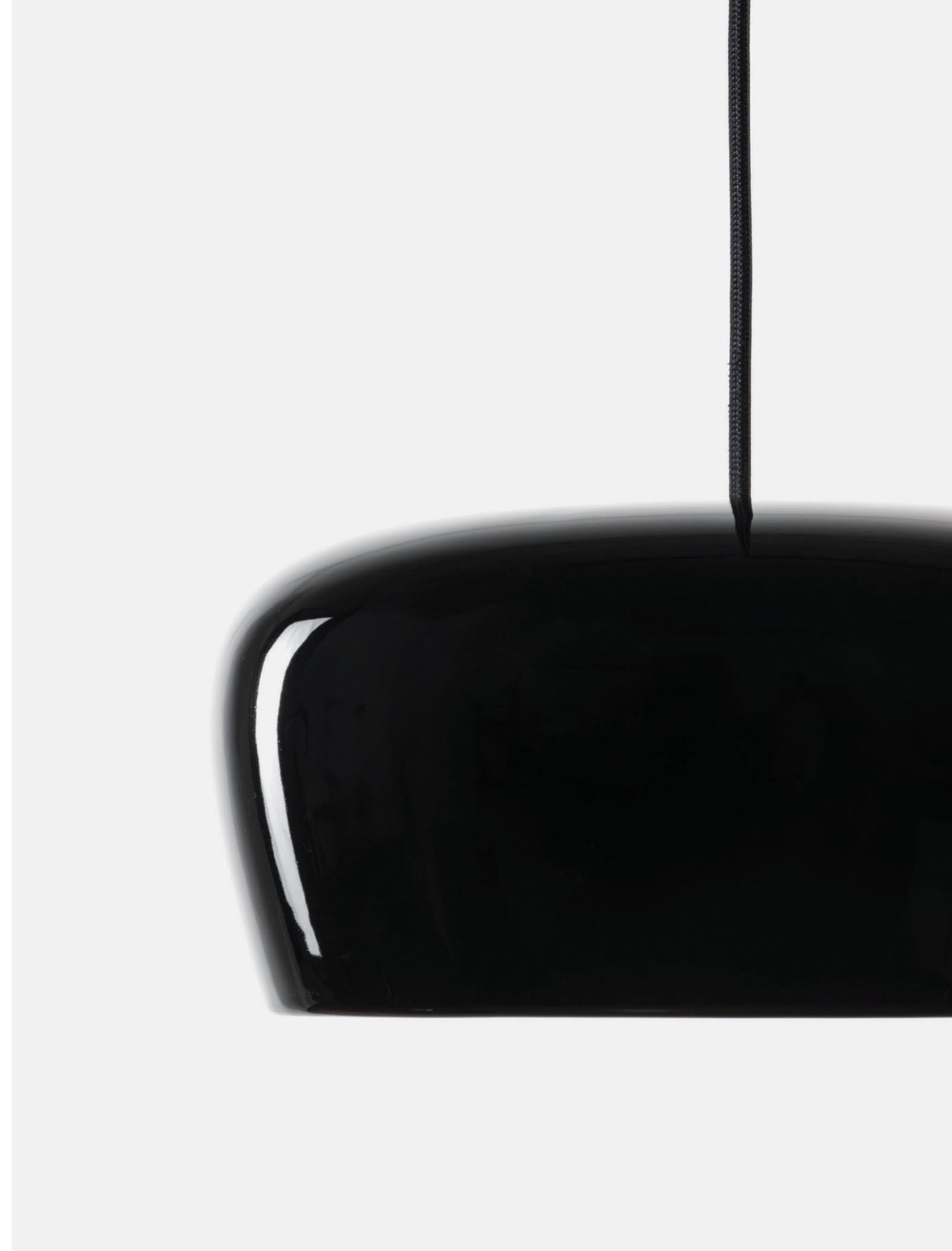



COPPOLA Chandelier 3

DESIGN  
MATERIAL  
FINISHES

Christophe de la Fontaine  
Ceramics  
White, White with Golden Reflector,  
Light Grey, Rose, Petrol with  
White Reflector, Black with  
Golden Reflector, Black with  
White Reflector, Gold with  
White Reflector, Copper with  
White Reflector, Platinum with  
White Reflector

LIGHT SOURCE

Fabric Covered Cable  
Each Unit 3,8 W LED, 700 mA, ca. 670 lm,  
CRI > 90, Warm White 2700 K  
Dimmable (Phase Cut)

ENERGY EFFICIENCY  
OTHER

A  
Shade Rotatable  
Overlength on Request  
Special Colors and Overlength on Request  
Canopy also available in Black on Request  
White Fabric Covered Cable available on Request

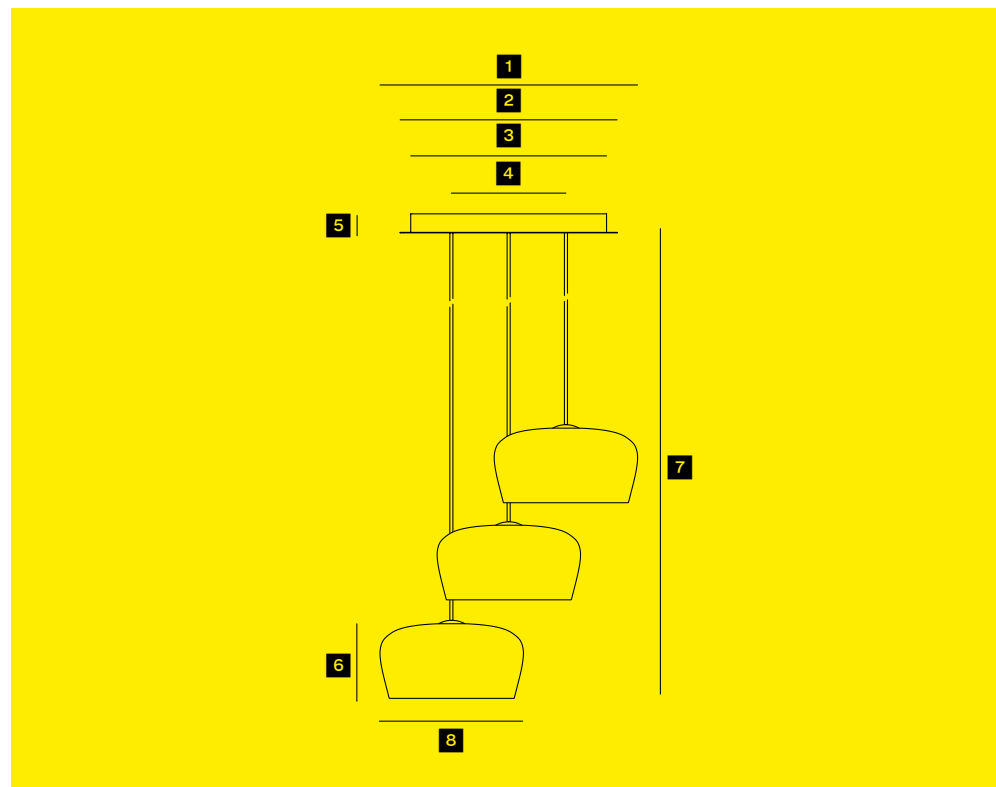

- 1 480 mm
- 2 410 mm
- 3 370 mm
- 4 216 mm
- 5 50 mm
- 6 140 mm
- 7 Max. 2500 mm  
Height Adjustable
- 8 270 mm





COPPOLA Table

DESIGN  
MATERIAL  
FINISHES

Christophe de la Fontaine  
Ceramics  
White, White with Golden Reflector,  
Light Grey, Rose, Petrol with  
White Reflector, Black with  
Golden Reflector, Black with  
White Reflector, Gold with  
White Reflector, Copper with  
White Reflector, Platinum with  
White Reflector  
Fabric Covered Cable  
1 × E27 LED-Globe, Ø 93-95 mm  
(Not Included)  
Depending on Lightbulb  
Cord Switch  
Shade Rotatable  
Excluding Lightbulb  
Special Colors on Request

LIGHT SOURCE

ENERGY EFFICIENCY

OTHER

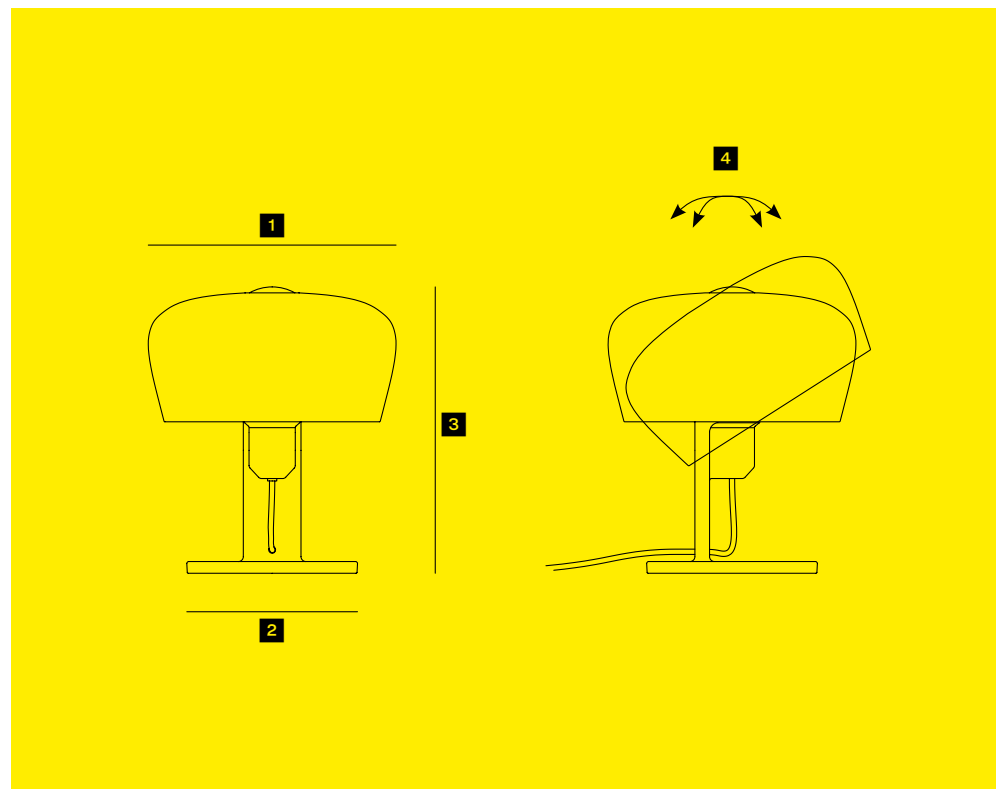

- 1 270 mm
- 2 180 mm
- 3 320 mm
- 4 75°







Two cones connect to form an iconic shape. The fascinating geometry makes DON CAMILLO a timeless classic with sculptural body language. The head is movable and its position changes the mood and perception of the object.

- Conic Iconic
- Sculptural Body Language
- Fascinating Geometry
- Timeless Classic
- Head Turns and Rotates
- Design by Benjamin Hopf

# DON CAMILLO

DON CAMILLO Table

DESIGN  
MATERIAL  
FINISHES

LIGHT SOURCE  
ENERGY EFFICIENCY  
OTHER

Benjamin Hopf  
Aluminium  
Glossy Black  
Glossy White  
1 × E27, max. 60 W (Not Included)  
Depending on Lightbulb  
Cord Switch  
Head Turns and Rotates  
Special Colours on Request

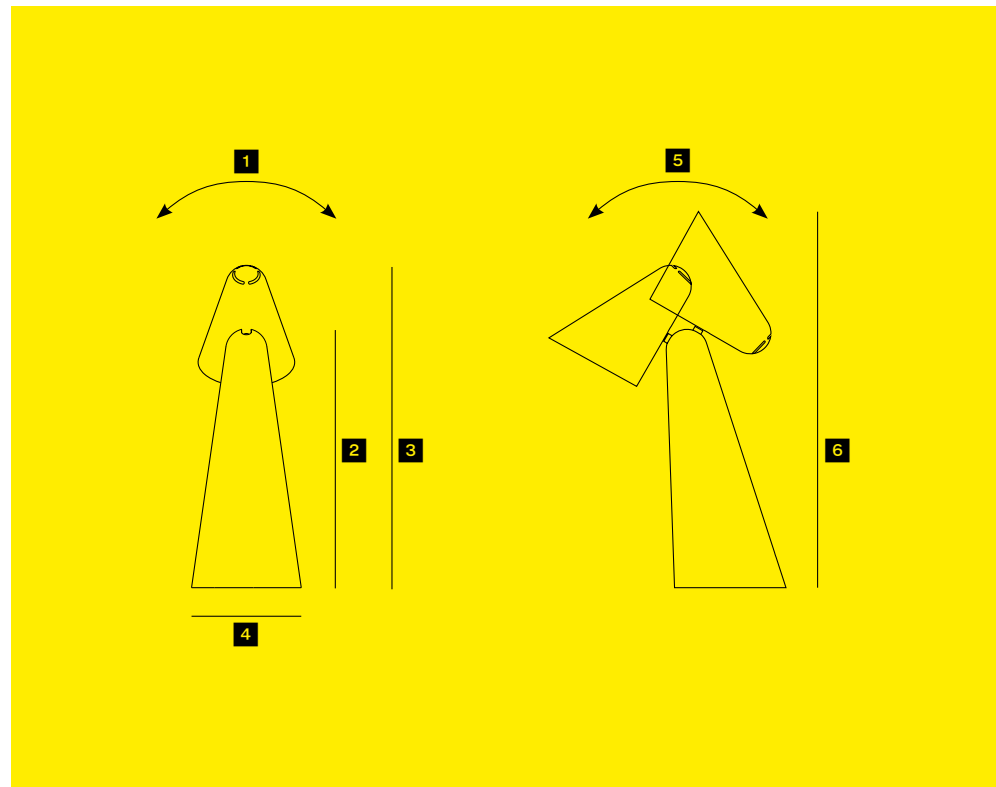

- 1 350°
- 2 375mm
- 3 470 mm
- 4 160 mm
- 5 350°
- 6 550 mm







DON CAMILLO Wall

DESIGN  
MATERIAL  
FINISHES  
LIGHT SOURCE  
ENERGY EFFICIENCY  
OTHER

Benjamin Hopf  
Aluminium  
Glossy Black  
Glossy White  
1 × E27, max. 60 W (Not Included)  
Depending on Lightbulb  
Dimmable (Depending on Lightbulb)  
Head Turns and Rotates  
With Button Switch on Request  
Special Colours on Request

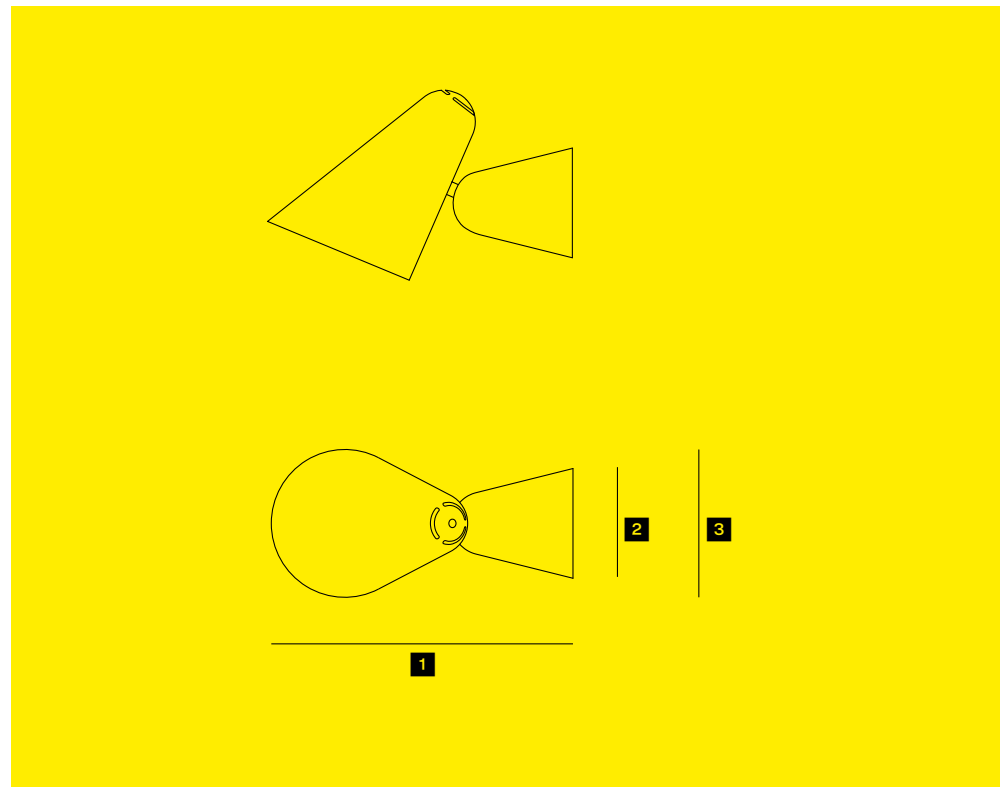

- 1** 285 mm
- 2** 100 mm
- 3** 140 mm



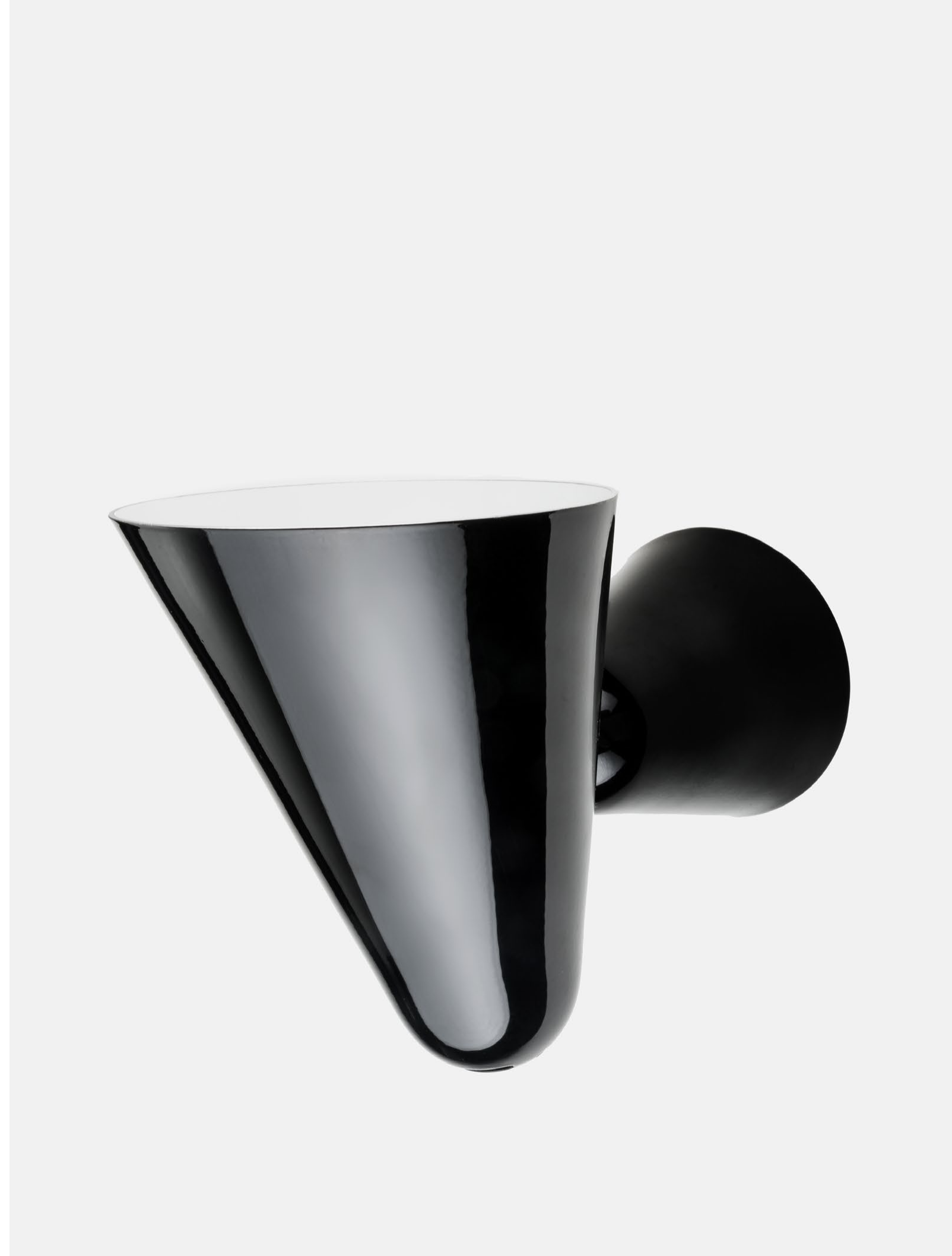



The table lamp E.T. is a helpful little buddy. The combination of pencil holder and light is convenient, provides space and maintains order. E.T. is very versatile and ideal for libraries, the reception desk, the small home office or the children's desk. The head can be swiveled and gives the object its own liveliness. Available in different colors E.T. will quickly find its new home.

- Multifunctional Product—Penholder and Lamp
- Light Adjustable
- Design by Benjamin Hopf

# E.T.

E.T. Table

DESIGN  
MATERIAL  
FINISHES  
LIGHT SOURCE  
ENERGY EFFICIENCY  
OTHER

Benjamin Hopf  
Aluminium, Steel  
Black, White, Orange, Gold (Brass)  
LED 3,1 W, 350 mA, 390 lm,  
CRI > 90, Warm White 2700 K  
D  
Transparent Cable with Cord Switch  
Plug-In Transformer

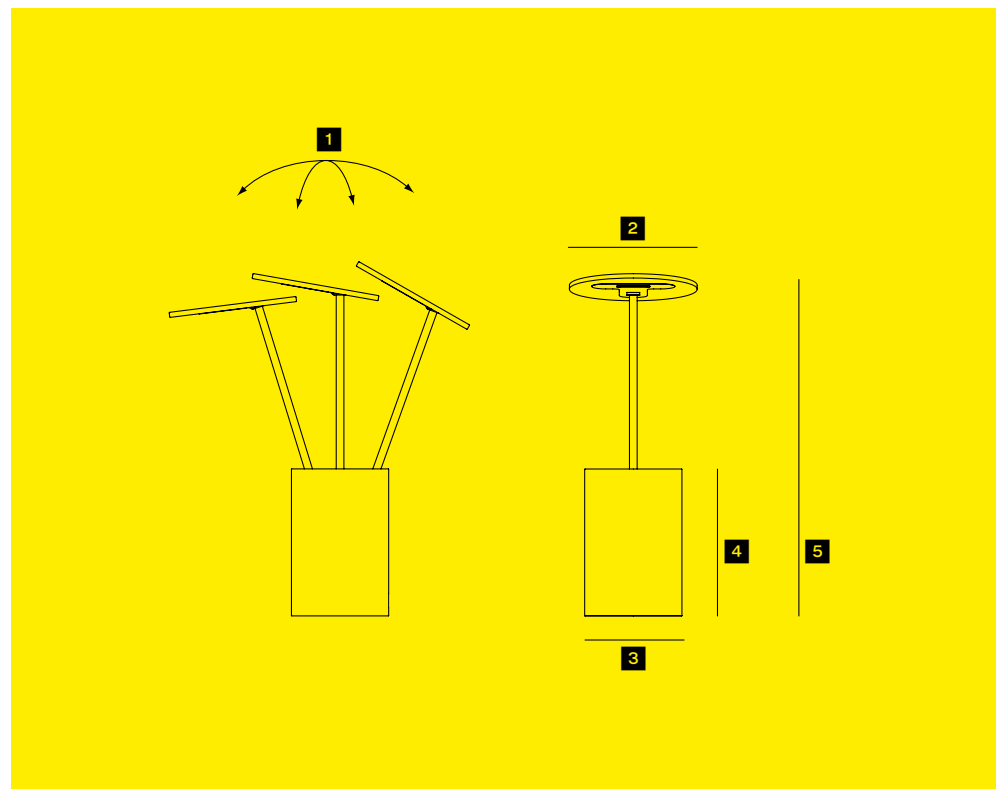

- 1 75°
- 2 100 mm
- 3 76 mm
- 4 115 mm
- 5 267 mm







The iconic shape makes PEPPONE a faithful little companion. The body language is charming and the compact size fits everywhere. The adjustable head allows for fundamentally different effects and gives PEPPONE a versatile character.

- Compact Size
- Iconic Shape
- Charismatic Body Language
- Serves Light Wherever Needed
- Adjustable Head Allows Fundamentally Different Effects
- Design by Benjamin Hopf
- Design and Design Int. Award

# PEPPONE

PEPPONE Table

DESIGN	Benjamin Hopf
MATERIAL	Aluminium
FINISHES	Black Matte, White Matte, Seasonal Colour
LIGHT SOURCE	Standard: LED 2,4 W, 350 mA, ca. 420 lm, CRI > 90, Warm White 2700 K Dimmable: LED 6,3 W, 700 mA, ca. 750 lm, CRI > 90, Warm White 2700 K
ENERGY EFFICIENCY	A
OTHER	Head Turns and Rotates Transparent Cable with Cord Switch Dimmable Version with Fabric Covered Cable and Touch Dimmer
AWARDS	Design and Design International Award

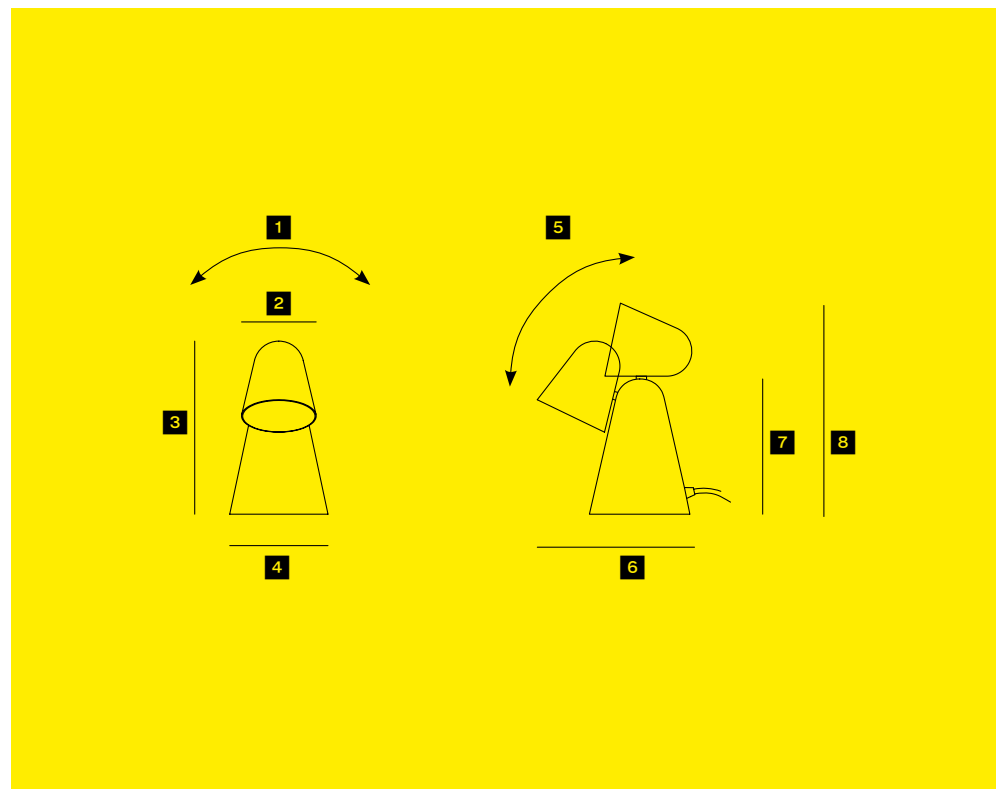

- 1 350°
- 2 95 mm
- 3 220 mm
- 4 125 mm
- 5 75°
- 6 195 mm
- 7 170 mm
- 8 265 mm







PEPPONE Wall

DESIGN  
MATERIAL  
FINISHES  
LIGHT SOURCE

ENERGY EFFICIENCY  
OTHER  
AWARDS

Benjamin Hopf  
Aluminium  
Black Matte, White Matte, Seasonal Colour  
Standard: LED 2,4 W, 350 mA, ca. 420 lm,  
CRI > 90, Warm White 2700 K  
Dimmable: LED 6,3 W, 700 mA, ca. 750 lm,  
CRI > 90, Warm White 2700 K  
A  
Head Turns and Rotates  
Design and Design International Award

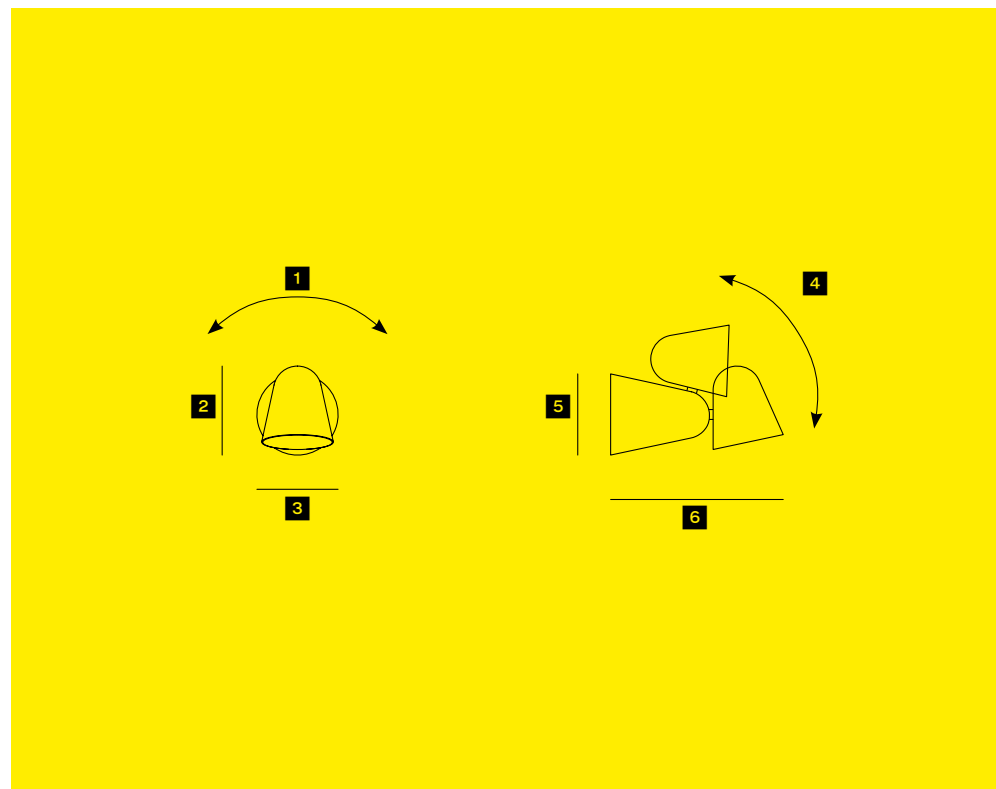

- 1 350°
- 2 116 mm
- 3 106 mm
- 4 75°
- 5 106 mm
- 6 226 mm

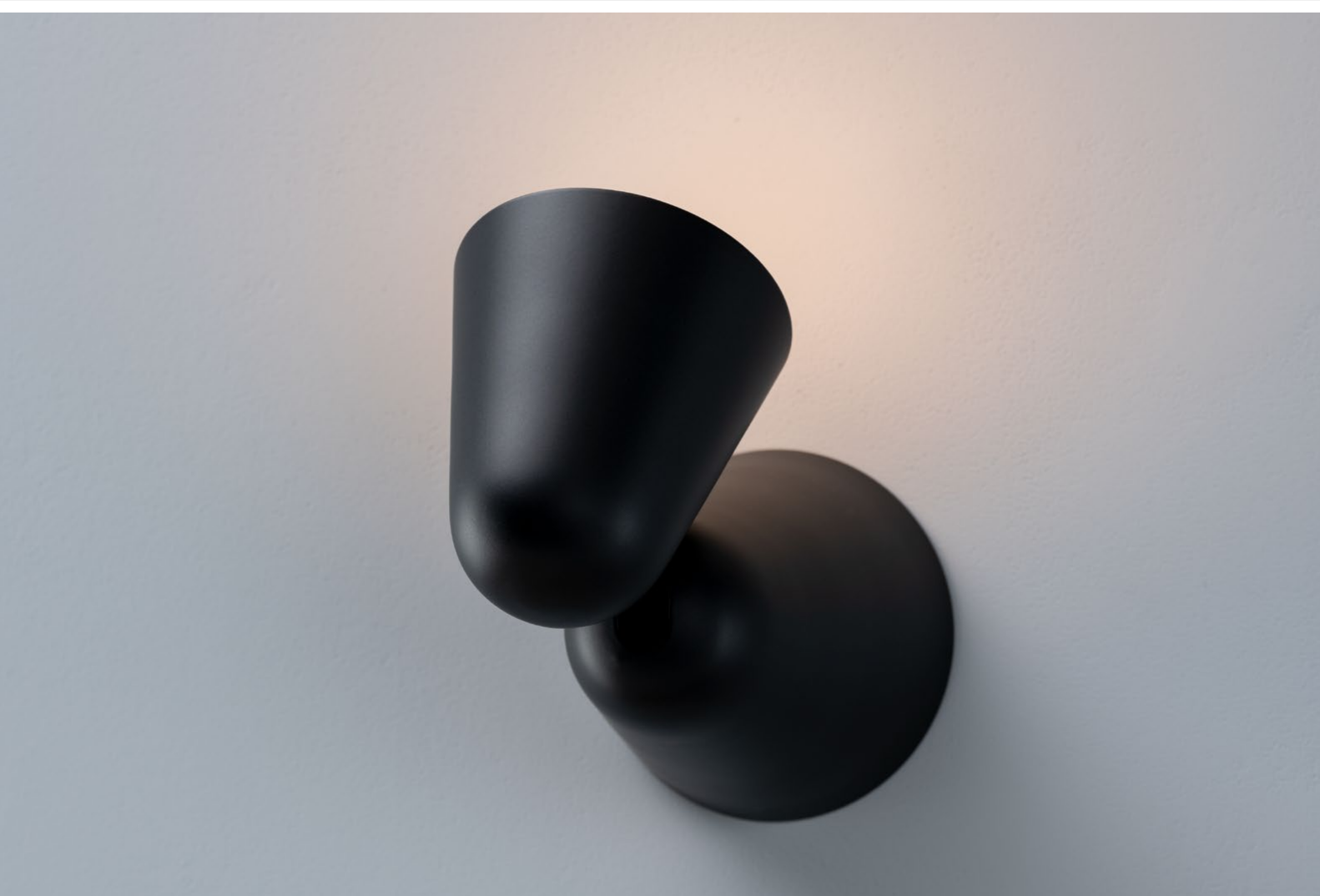

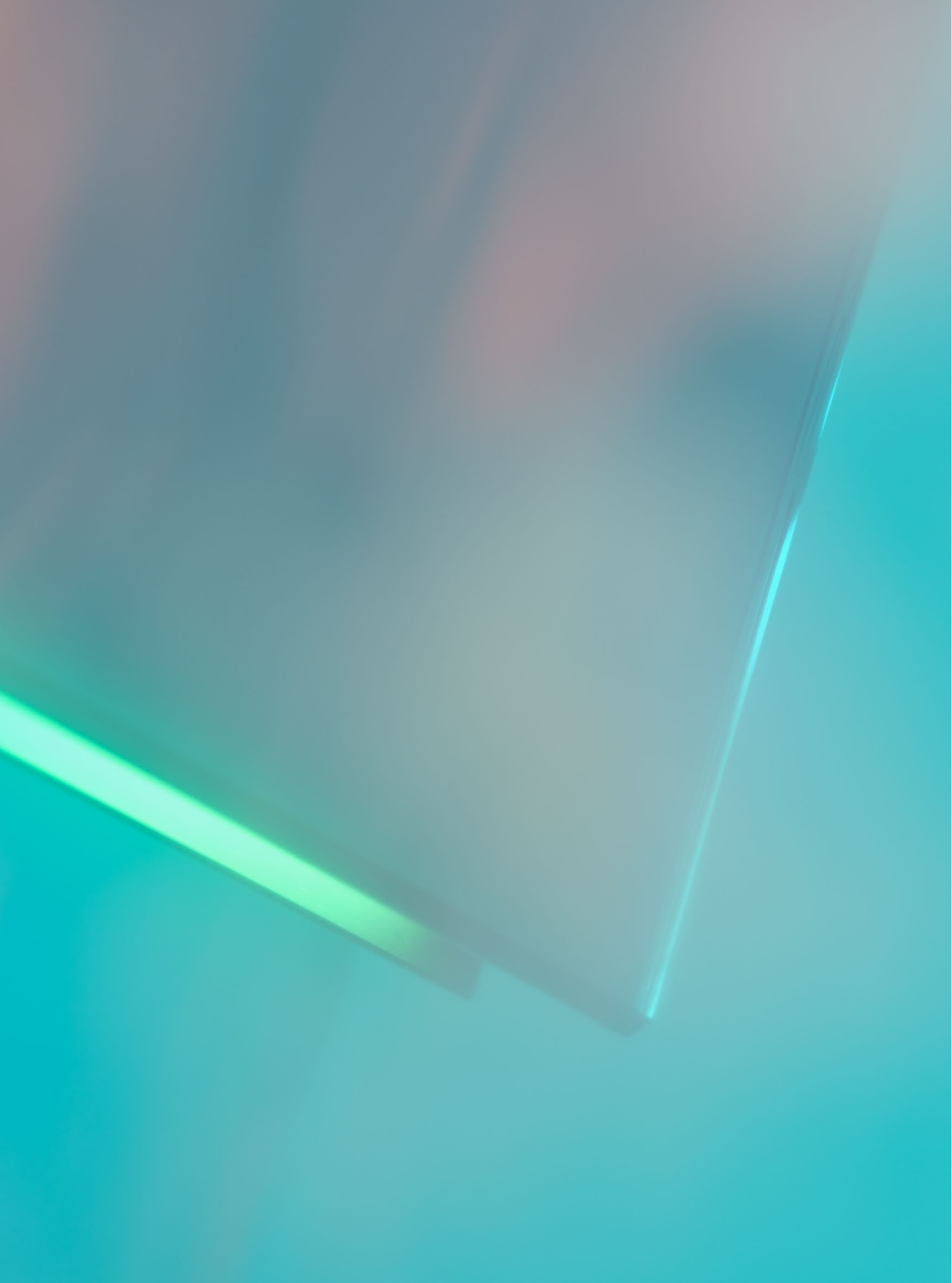

MIRROR MIRROR ... makes your dreams come true. The futuristic design is like a chameleon. It fits to any interior and a second space level lives in its reflection. The pure geometric shape features elegant details and yet maintains minimalistic aesthetics. The MIRROR family comes in three different formats: small, square, wide—and three finishes: clear mirror, smoked grey mirror, multicolor mirror.

- Minimal to the Maximum
- Nice Details in Pure Geometric Shape
- Reflection Adds a Second Space Level
- Fairy-Tale Magic vs. Modern Futuristic
- Chameleon Relation to Every Interior

# MIRROR

MIRROR Small Suspension

DESIGN

MATERIAL

FINISHES

LIGHT SOURCE

ENERGY EFFICIENCY

OTHER

Benjamin Hopf

Mirror, Aluminium

Clear Mirror, Smoked Grey Mirror,

Multicolour Mirror

LED 3,1 W, 500 mA, ca. 420 lm,

CRI > 90, Warm White 2700 K

C

Dimmable (Phase Cut), DALI on Request

Custom Finishes on Request

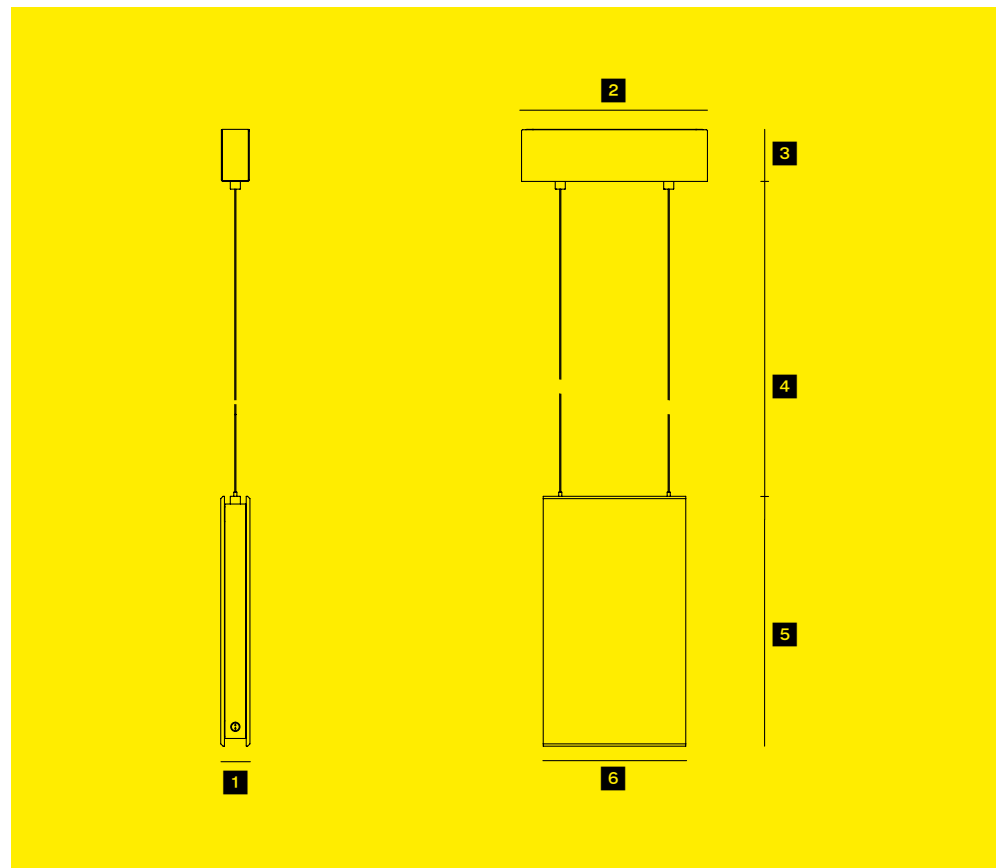

- 1 36 mm
- 2 240 mm
- 3 65 mm
- 4 Max . 2000 mm  
Overlength on Request
- 5 320 mm
- 6 184 mm





MIRROR Square Suspension

DESIGN Benjamin Hopf  
MATERIAL Mirror, Aluminium  
FINISHES Clear Mirror, Smoked Grey Mirror, Multicolour Mirror  
LIGHT SOURCE LED 5,8W, 700 mA, ca. 750 lm, CRI > 90, Warm White 2700 K  
ENERGY EFFICIENCY C  
OTHER Dimmable (Phase Cut), DALI on Request  
Custom Finishes on Request

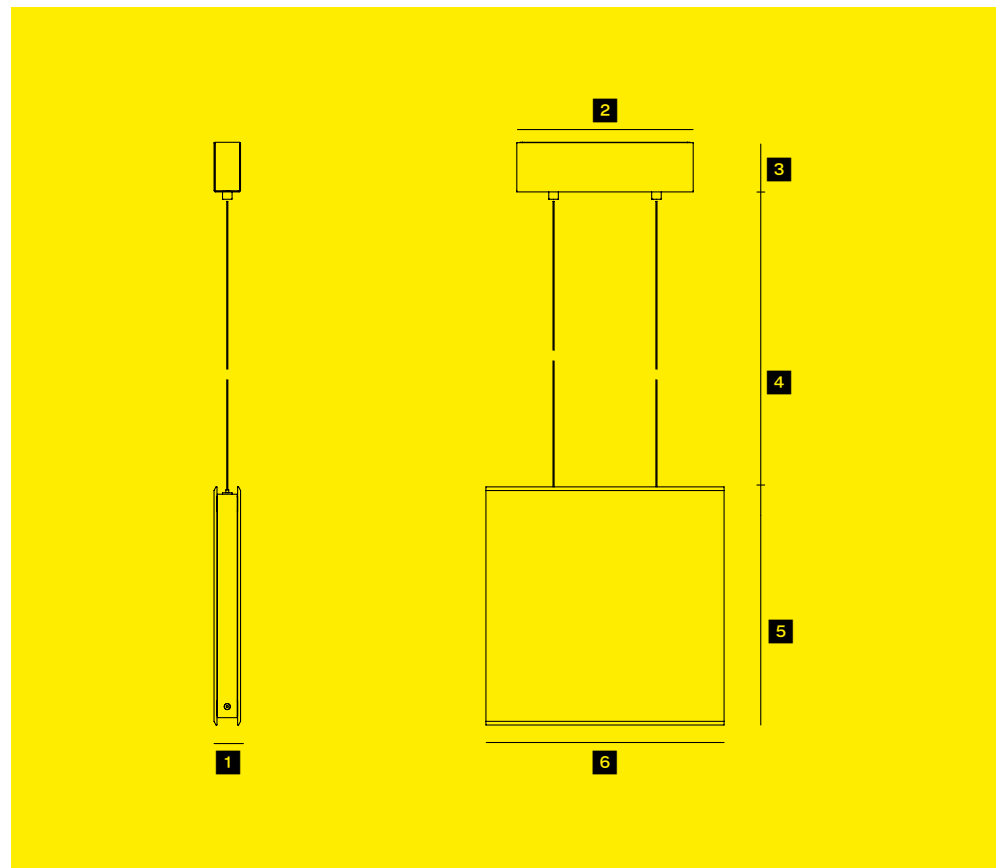

- 1 36 mm
- 2 240 mm
- 3 65 mm
- 4 Max . 2000 mm  
Overlength on Request
- 5 320 mm
- 6 320 mm



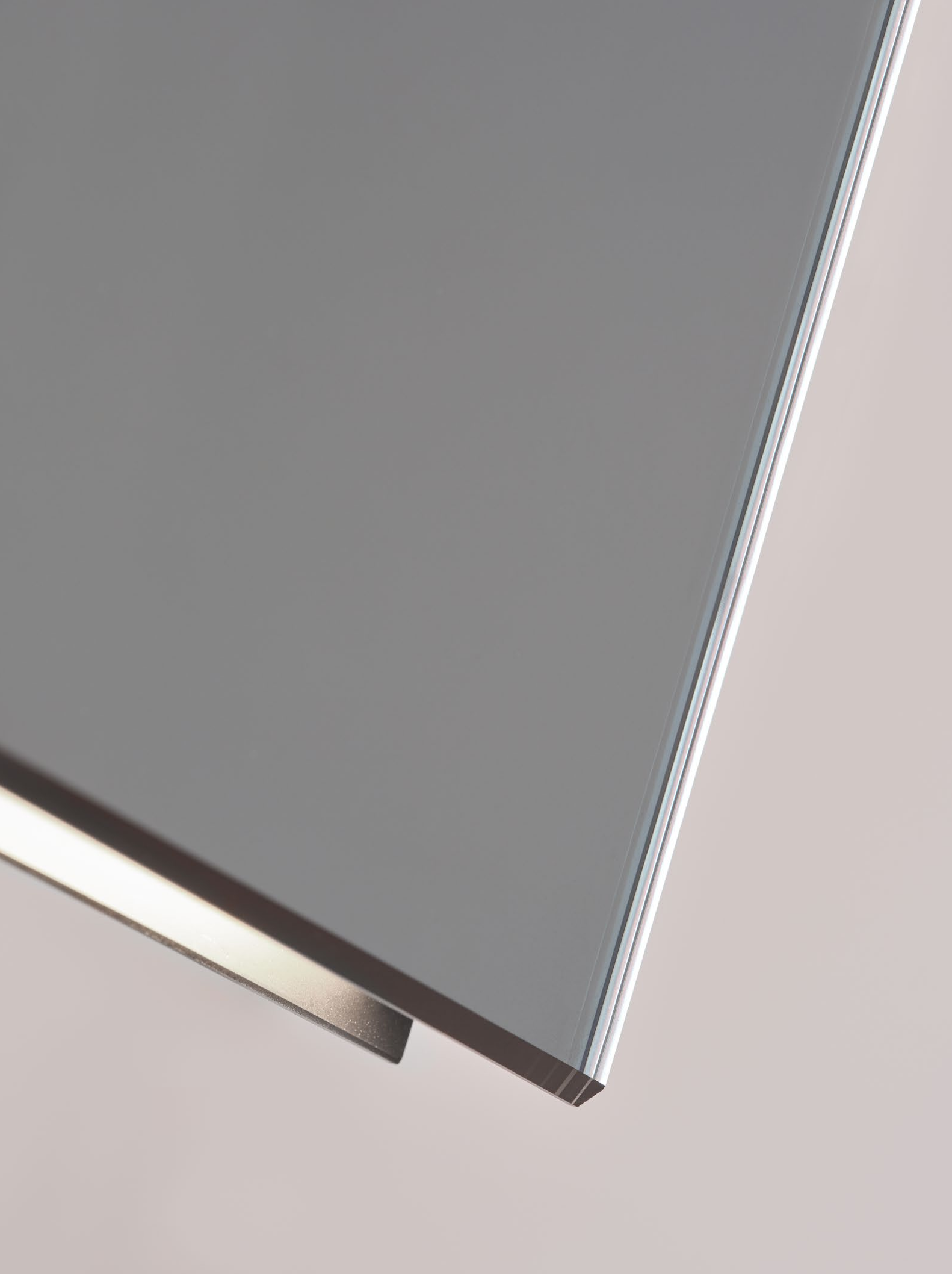



MIRROR Wide Suspension

DESIGN	Benjamin Hopf
MATERIAL	Mirror, Aluminium
FINISHES	Clear Mirror, Smoked Grey Mirror, Multicolour Mirror
LIGHT SOURCE	LED 17,4 W, 700 mA, ca. 2100 lm, CRI > 90, Warm White 2700 K
ENERGY EFFICIENCY	C
OTHER	Dimmable (Phase Cut), DALI on Request Custom Finishes on Request

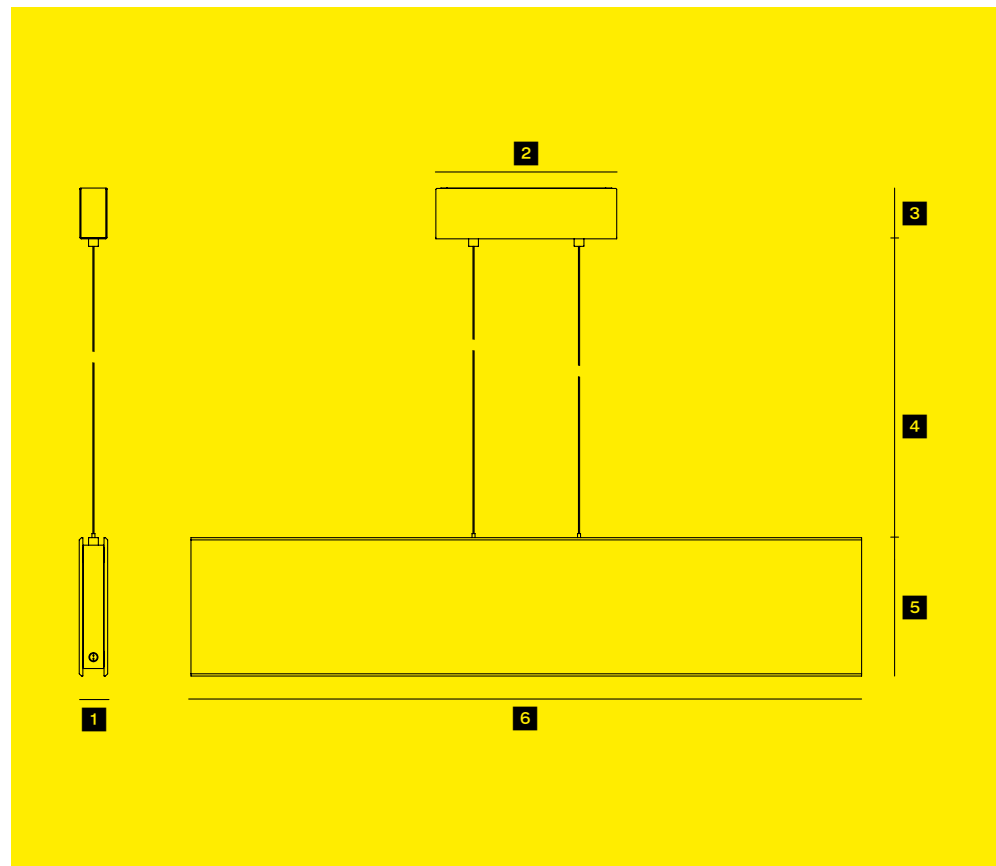

- 1 36 mm
- 2 240 mm
- 3 65 mm
- 4 Max . 2000 mm  
Overlength on Request
- 5 185 mm
- 6 890 mm

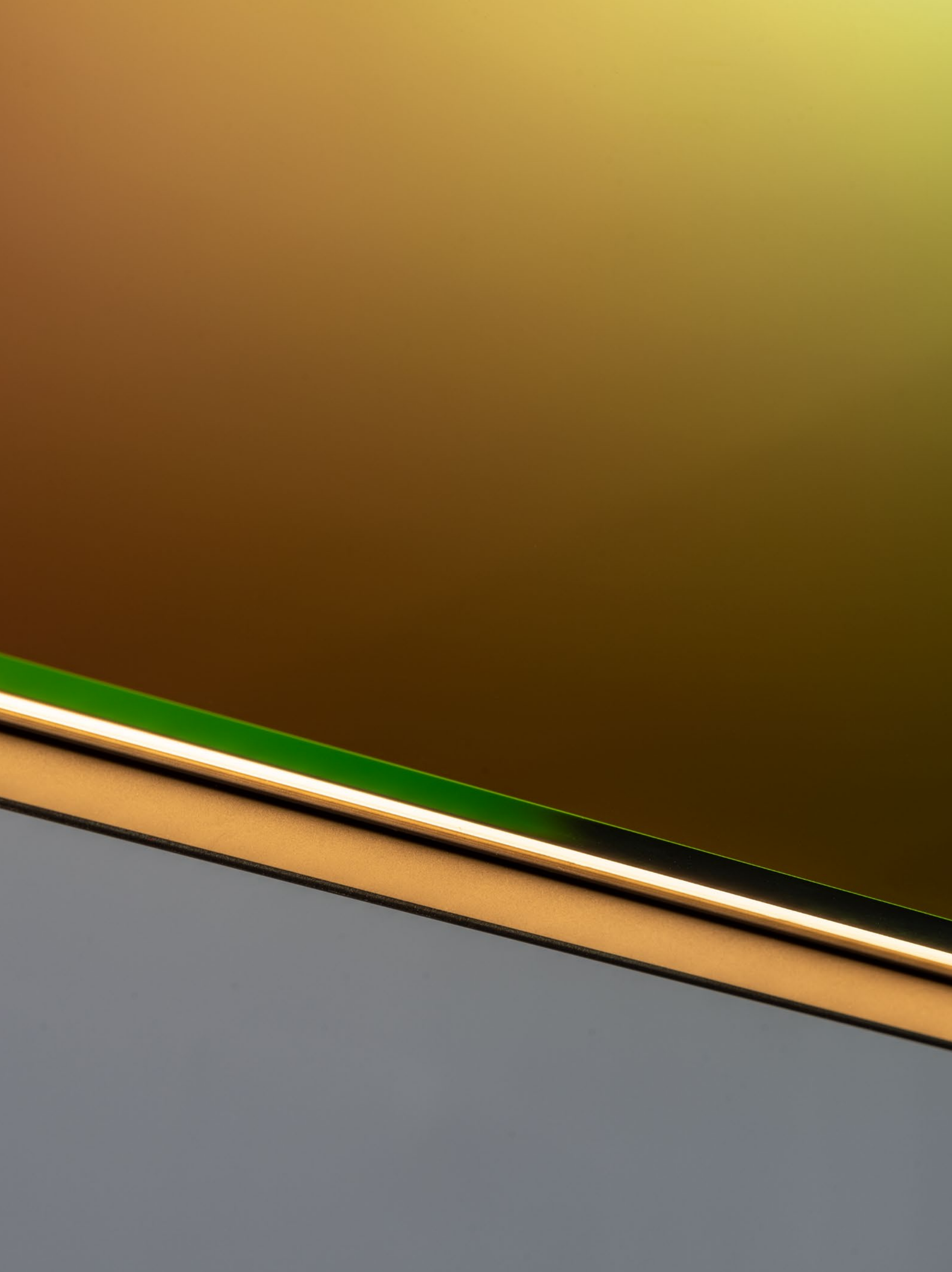

© 2022 FORMAGENDA GMBH  
THE NEW ENLIGHTENMENT

COPY  
Lukas Kubina

ART DIRECTION  
WIEGAND VON HARTMANN

PHOTOGRAPHY  
Aylin Langreuter  
Felix Brandl  
Gerhardt Kellermann  
Henning Bornemann  
Kaveh Kasravi  
Kilian Brees  
Manuel Nieberle  
SCHMOTT Studios  
Sonja Müller

TECHNISCHE UND FORMALE ÄNDERUNGEN VORBEHALTEN  
SUBJECT TO ALTERATION WITHOUT NOTICE

MÜNCHNER FREIHEIT 24  
80802 MÜNCHEN  
GERMANY

INFO@FORMAGENDA.COM  
+49 89 414240880  
WWW.FORMAGENDA.COM